

Dal 1° produttore di parti di ricambio per
l'industria delle materie plastiche

Per chi trasforma le materie plastiche
Tutto quello che serve in reparto

PMS

nickerson
Italia

Agente PMS per l'Italia:

NICKERSON ITALIA S.r.l.

Via Ardarò, 49
38062 RIVA DEL GARDA (TN)

TEL. 0464 554094

FAX 0464 563362

e-mail : sales@nickerson.it

Internet: www.nickerson.it



VITI E CILINDRI



PUNTALI



STAFFE



RACCORDI



FLUSSOMETRI



TUBI



PINZE E TRONCHESI



GRIGLIE E MAGNETI



DISTACCANTI E GRASSI



VENTOSE



RESISTENZE



UGELLI

RICHIEDETE GRATUITAMENTE E SENZA IMPEGNO IL NOSTRO CATALOGO

Staffe Forgiate

Staffe chiuse

Staffe a forcella

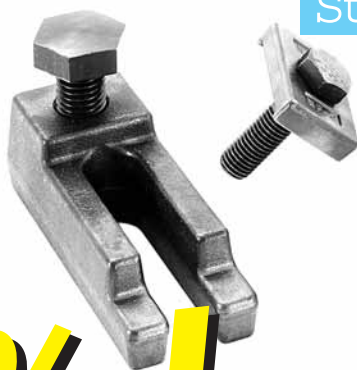

-15 % !

Tipo	Lunghezza	Bullone	Codice	Prezzo speciale dell'insieme completo in euro	
Staffa chiusa completa	108 mm	12/1,75 mm	AC0FCZ	23,05	19,59
	133 mm	16/2 mm	AC1FCZ	25,29	21,50
	133 mm	20/2,5 mm	AC2FCZ	30,42	25,86
	178 mm	16/2 mm	AC3FCZ	36,02	30,61
	178 mm	20/2,5 mm	AC4FCZ	38,52	32,75
	178 mm	24/3 mm	AC5FCZ	45,62	38,78
	240 mm	24/3 mm	AC9FCZ	58,42	49,66
Staffa a forcella completa	305 mm	30 mm	AC12FCZ	67,23	57,15
	133 mm	16/2 mm	AC1FOZ	25,23	21,45
	133 mm	20/2,5 mm	AC2FOZ	30,42	25,86
	178 mm	16/2 mm	AC3FOZ	36,02	30,61
	178 mm	20/2,5 mm	AC4FOZ	38,42	32,66

Opzioni di installazione

Fissaggio standard



Bullone da 90 mm

Fissaggio < 23 mm

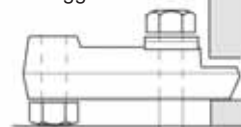

Bullone da 90 mm

Fissaggio > 23 mm

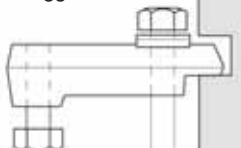

Bullone da 110 mm

Sono inclusi: staffa, bullone, rondella, vite di regolazione.

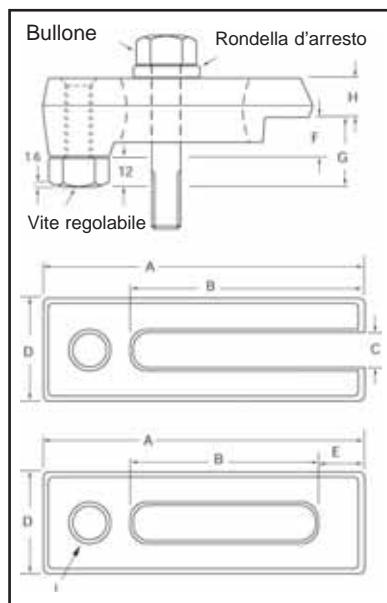

Finitura brunita, resistente alla corrosione.
Staffe forgiate in acciaio di qualità superiore.

Code PMS	long. A	C	B	larg. D	F	G	H	E	I
AC0FC	108mm	14.3	51	38	23	35	16	24	1/2"-13
AC1FC	133mm	17.5	64	50	23	35	18.3	28	3/4"-10
AC2FC	133mm	20.6	64	50	23	35	18.3	28	3/4"-10
AC3FC	178mm	17.5	100	50	23	35	18.3	35	3/4"-10
AC4FC	178mm	20.6	100	50	23	35	18.3	35	3/4"-10
AC5FC	178mm	27	100	67	35	48	18.3	38	3/4"-10
AC9FC	240mm	27	133	67	35	48	18.3	38	3/4"-10
AC12FC	305mm	33	160	76	35	51	18.3	42	1"-8
AC1FO	133mm	17.5	89	50	23	35	18.3		3/4"-10
AC2FO	133mm	20.6	89	50	23	35	18.3		3/4"-10
AC3FO	178mm	17.5	125	50	23	35	18.3		3/4"-10
AC4FO	178mm	20.6	125	50	23	35	18.3		3/4"-10

Flussometri

Flussometri

GAMMA QUALITA' PREMIUM

Flussometri speciali per la trasformazione delle materie plastiche

La posizione del galleggiante incorporato permette di visualizzare le variazioni di flusso in relazione ai dati preselezionati.

Tubo - specula in PC rimovibile per facilitare la pulizia

A richiesta - Tasso di flusso:

da 0 a 10 l/min oppure da 0 a 20 l/min.

Numero di zone	Lunghezza mm	Ref.	Prezzo unit. in euro
1	72	FR1Z	199,50
2	124	FR2Z	245,70
3	176	FR3Z	334,95
4	228	FR4Z	414,75
5	281	FR5Z	510,62
6	334	FR6Z	598,71
8	438	FR8Z	774,80
10	545	FR10Z	942,06
12	649	FR12Z	1123,40

Galleggianti		
litri/min.	Ref.	Prezzo unit. in euro
10	FC10	2,50
20	FC20	2,50

Joints O-rings		
Ref.	Prezzo unit. in euro	
22001	1,03	
22002	2,05	
22003	1,03	
22004	2,05	
22005	0,98	
29012	0,98	
29016	0,73	

Tubo graduato		
Numero	Ref.	Prezzo unit. in euro
10 - 20	12003	20,10

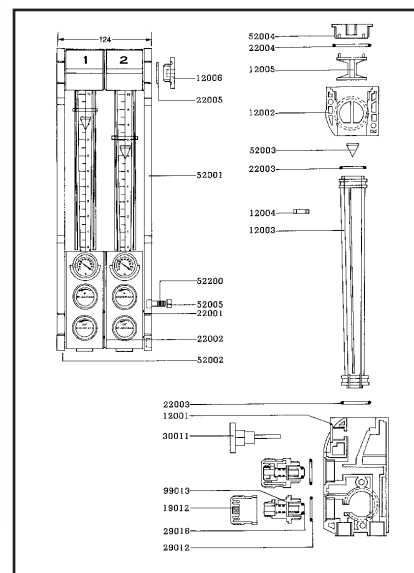
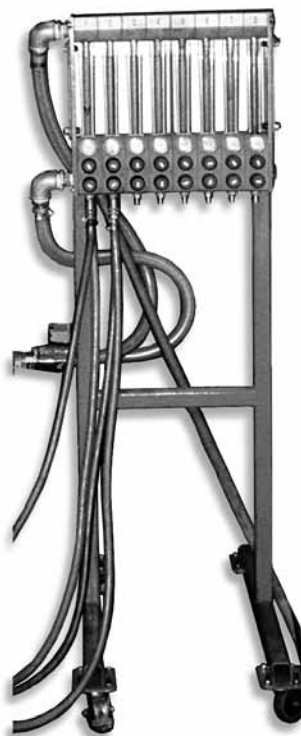

Flussometri economici

NUOVA GAMMA DI FLUSSOMETRI ECONOMICI

Caratteristiche tecniche :

Tubo in PA12 totalmente trasparente e facile da pulire
Corpi inferiori e superiori in PA6 rinforzata con 30% di fibra di vetro per una migliore resistenza.

Teste dei raccordi forniti.

Albero di fissaggio in acciaio Inox.

Termometri indipendenti su ogni zona.

Interamente smontabili.

Numero di zone	Lunghezza mm	Ref.	Prezzo unit. in euro
1	80	ICM01	142,80
2	140	ICM02	176,40
3	200	ICM03	231,67
4	260	ICM04	273,00
5	320	ICM05	367,49
6	385	ICM06	399,00
8	505	ICM08	496,65
10	630	ICM10	624,75
12	750	ICM12	787,50

NOVITA'



Raccordi acqua

Raccordi acqua

100% compatibile DME !

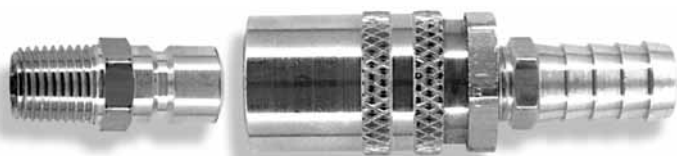

Connettore sfilabile

Raccordi forniti insieme alle teste.

Per teste senza raccordi, vedere la pagina seguente.



Raccordi a gomito a 90°



Raccordi a gomito a 45°



Raccordi dritti

PREZZO

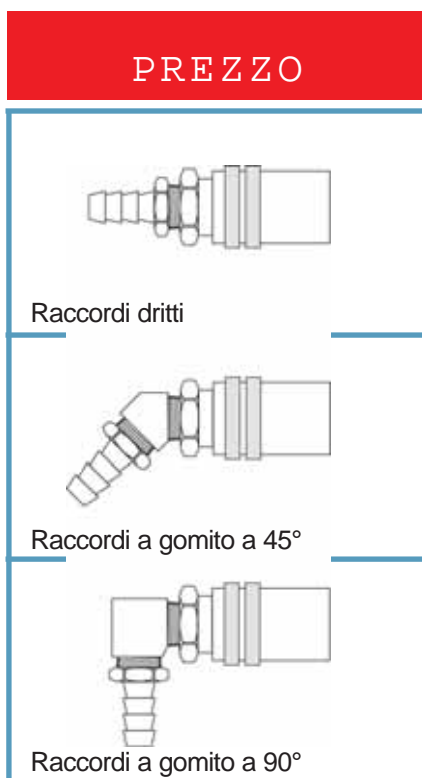

Raccordi dritti

Raccordi a gomito a 45°

Raccordi a gomito a 90°

Serie	Ø int (mm)	Ø interno del tubo (mm)	Raccordi (passaggio aperto)	
			Ref.	Prezzo speciale!
200	4,7	6,4 (1/4")	MF204	3,51
	5,6	8,0 (5/16")	MF205	3,66
	6,0	9,5 (3/8")	MF206	3,66
300	7,3	9,5 (3/8")	MF306	4,88
	9,6	12,7 (1/2")	MF308	5,03
500	9,6	12,7 (1/2")	MF504	10,98
	14,3	19,0 (3/4")	MF506	11,28
200	4,7	6,4 (1/4")	MF224	4,27
	5,6	8,0 (5/16")	MF225	4,27
	6,0	9,5 (3/8")	MF226	4,27
300	7,3	9,5 (3/8")	MF326	6,25
	9,6	12,7 (1/2")	MF328	6,56
500	9,6	12,7 (1/2")	MF524	15,24
	14,3	19,0 (3/4")	MF526	15,24
200	4,7	6,4 (1/4")	MF214	4,27
	5,6	8,0 (5/16")	MF215	4,42
	6,0	9,5 (3/8")	MF216	4,42
300	7,2	9,5 (3/8")	MF316	6,10
	9,6	12,7 (1/2")	MF318	6,56
500	9,6	12,7 (1/2")	MF514	15,24
	14,3	19,0 (3/4")	MF516	15,24

Raccordi (chiusura automatica)	
Ref.	Prezzo speciale!
MF204V	6,71
MF205V	6,86
MF206V	6,86
MF306V	7,77
MF308V	7,77
MF224V	7,47
MF225V	7,47
MF226V	7,47
MF326V	9,91
MF328V	10,06
MF214V	6,86
MF215V	7,32
MF216V	6,86
MF316V	9,15
MF318V	9,45

Attacchi per raccordi

Attacco maschio



Attacco femmina



Scala 1:1

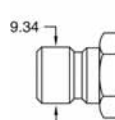

Serie 200

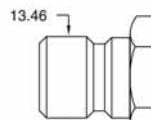

Serie 300

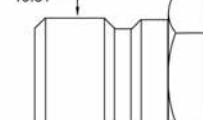

Serie 500

PREZZO

Diametro passaggio acqua	Filetto tubo	Attacco maschio	
		Ref.	Prezzo speciale !
6,4 mm (1/4")	1/8" BSP	MP251	0,64
	1/4" BSP	MP252	0,64
	3/8" BSP	MP253	0,79
9,5 mm (3/8")	1/8" BSP	MP351	0,79
	1/4" BSP	MP352	0,79
	3/8" BSP	MP353	0,91
	1/2" BSP	MP354	1,35
12,7 mm (1/2")	1/2" NPT	MP554	2,27
	3/4" NPT	MP556	3,28

Attacco maschio

Attacco femmina

Ref.	Prezzo speciale !
FP251	0,66
FP252	0,79
FP253	1,14
FP351	1,14
FP352	0,79
FP353	0,95
FP554	4,57
FP556	5,64

Raccordi acqua

Attacchi rapidi a passaggio libero, tipo

Circuiti d'acqua fredda, refrigerata, acqua e olii caldi nelle attrezzature.

Perfettamente compatibili e adattabili sui vostri raccordi attuali, questi raccordi sono di qualità molto alta. Fabbricati in serie industriale, vi permettono di realizzare economie molto importanti.

Parti, corpo e strutture in ottone nichelato; molle e biglie in acciaio inox.

Guarnizioni in nitrile (NBR) standard, Viton, o altro a richiesta.

Pressione di esercizio: 20 bars.

Disponibile a stock anche la gamma CPL12

ATTACCHI	Filetto	TIPO CPL08		
		Ref.	Prezzo in euro 1 - 50 51 e +	
Femmina filettato	1/4"	CPL0831140	7,15	6,72
Femmina maschiato	1/4"	CPL086101	6,50	6,11
	3/8"	CPL08021380	7,80	7,33
	1/2"	-	-	-
Femmina condotto autobloccante	(3/8) ø 10	CPL086810/CN	5,40	5,08
	(1/2) ø 13	CPL086813/CN	5,40	5,08
	(5/8) ø 16	-	-	-
Femmina per tubi	ø 8	CPL086808	5,40	5,08
	ø 10	CPL086810	5,40	5,08
	ø 12	CPL086812	5,40	5,08
	ø 13	-	-	-
Femmina 90° maschiato	1/4"	CPL086101/RE	11,98	11,26
	3/8"	-	-	-
	1/2"	-	-	-
Femmina 90° per tubi	ø 8	CPL086808/RE	10,90	10,25
	ø 10	CPL086810/RE	10,90	10,25
	ø 12	CPL086812/RE	10,90	10,25
	ø 13	-	-	-
Femmina 90° autobloccante	ø 10	CPL086810CN/RE	10,90	10,25
	ø 13	CPL086813CN/RE	10,90	10,25
	ø 16	-	-	-
	ø 10	-	-	-
Femmina 135° maschiato	1/4"	CPL086101/RO	11,30	10,62
	1/2"	-	-	-
Femmina 135° per tubi	ø 8	CPL086808/RO	13,30	12,50
	ø 10	CPL086810/RO	13,30	12,50
	ø 12	CPL086812/RO	13,30	12,50
	ø 13	-	-	-
	ø 16	-	-	-
Femmina 135° autobloccante	(3/8) ø 10	CPL086810CN/RO	13,90	13,07
	(1/2) ø 13	CPL086813CN/RO	13,90	13,07
	(5/8) ø 16	-	-	-

ATTACCHI	Filetto	TIPO CPL08			
		Ref.	Prezzo in euro 1 - 50 51 e +		
Maschio maschiato	1/8"	CPL081100	1,77	1,66	
	1/4"	CPL081101	1,77	1,66	
	3/8"	-	-	-	
	1/2"	-	-	-	
Maschio filettato	10x100	CPL081410	1,52	1,43	
	10x150	CPL081415	1,52	1,43	
	1/8"	CPL081150	1,30	1,22	
	1/4"	CPL081151	1,30	1,22	
	3/8"	CPL081152	1,30	1,22	
	1/2"	-	-	-	
Maschio 90° filettato	1/8"	CPL081150/RE	3,96	3,72	
	1/4"	CPL081151/RE	3,96	3,72	
	3/8"	CPL081152/RE	3,96	3,72	
Maschio 90° maschiato	1/2"	-	-	-	
	1/8"	CPL081100/RE	3,96	3,72	
	1/4"	CPL081101/RE	3,96	3,72	
	3/8"	CPL081102/RE	3,96	3,72	
Prolunga monoblocco	Lg 50	CPL081010/50RF	3,70	3,48	
	Lg 100	CPL081010/100RF	5,35	5,03	
	Lg 150	CPL081010/150RF	6,40	6,02	
	Lg 200	CPL081010/200RF	8,85	8,32	
	Lg 250	CPL081010/250RF	12,80	12,03	
	Lg 50	CPL081011/50RF	3,70	3,48	
Guarnizioni	Alta temperatura	nitrile	JOO711	0,20 0,15	
		VITON	-	0,30 0,25	
		-	-	-	
	Filetto 1/8"	Lg 100	CPL081011/100RF	5,35	5,03
		Lg 150	CPL081011/150RF	6,40	6,02
		Lg 200	CPL081011/200RF	8,85	8,32
Lg 250		CPL081011/250RF	12,80	12,03	
Filetto 1/4"		Lg 100	CPL081011/100RF	5,35	5,03
		Lg 150	CPL081011/150RF	6,40	6,02
	Lg 200	CPL081011/200RF	8,85	8,32	

Tubi in PVC

Tubo PVC rinforzato con fibre di poliestere trasparente o in PVC/PU colorato.

Resiste agli olii e ai tagli, grande flessibilità e buona resistenza a temperature elevate.

T° da -15+ a +60°C.

Corona di 25 m



PVC Transparente

ø Int. mm	Raccordi	ø est. mm	Pressione di esercizio a 20°C	Ref.	1 a 2	-15%
6	1/4"	12	250psi	PWLH250	32,08	27,27
8	5/16"	14	200psi	PWLH312	36,41	30,95
10	3/8"	16	180psi	PWLH375	37,80	32,13
13	1/2"	20	150psi	PWLH500	44,21	37,58
19	3/4"	27	100psi	PWLH750	84,11	71,49
25	1"	34	80psi	PWLH1000	124,45	111,73
Colore rosso						
6	1/4"	12	250psi	PWLH250R	36,41	30,95
8	5/16"	14	200psi	PWLH312R	43,70	37,15
10	3/8"	16	180psi	PWLH375R	51,90	44,12
13	1/2"	20	150psi	PWLH500R	66,46	56,49
19	3/4"	27	100psi	PWLH750R	85,84	72,96
Colore blu						
6	1/4"	12	250psi	PWLH250B	36,41	30,95
8	5/16"	14	200psi	PWLH312B	43,70	37,15
10	3/8"	16	180psi	PWLH375B	51,90	44,12
13	1/2"	20	150psi	PWLH500B	66,46	56,49
19	3/4"	27	100psi	PWLH750B	85,84	72,96

Altre dimensioni a richiesta

Pinze e Tronchesi

Pinze speciali per decarotaggio

Pinze speciali per materie plastiche..

Senza smussatura, taglio a filo di carota d'iniezione
Superficie di taglio liscia e piatta. Con molla d'apertura.

Progettazione specifica per il decarotaggio dei pezzi in materiale plastico.
Sono state studiate appositamente per ridurre lo sforzo degli operatori e assicurare una qualità di taglio perfetta.



	Tipo	L	A	B	C	REF	Prezzo speciale unitario in €
 15°	Lama piatta	117	16	4,8	18	FF4	15,10 14,80
		127	16	4,8	19	FF5	15,10 14,80
		145	19	6,4	22	GR5	14,10 13,80
		155	19	4,8	21	FF6	17,40 17,00
		190	25	6,4	25	FF7	18,20 17,70
 20°	Lama curva	117	17,5	4,8	18	S4	15,10 14,80
		127	16	3,2	16	S5	15,10 14,80
		158	19	6,4	22	S6	17,40 16,70
		190	25	6,4	25	S7	19,60 18,80
 45°	Lama a gomito 45°	150	19	6,4	25	GA5	17,40 17,00
		166	19	6,4	25	GA7	19,10 18,30
		140	9,5	6	25	GA6	29,73 28,97
 90°	Lama a gomito 90°						

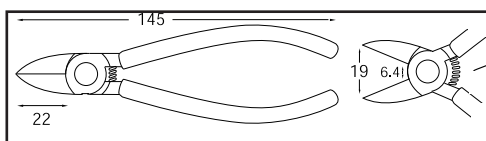

Lame trattate



Standard :
con lame a gomito a 15°
Lame fini di precisione elevata



Le lame fini di precisione elevata garantiscono una finitura professionale del pezzo stampato



Taglio diagonale, lame a gomito a 45°



Taglio diagonale, lame a gomito a 90°

Pinze pneumatiche - grande potenza

● A MANO

MR10A
TRONCHESE
PREZZO: € 181,75
POTENZA DI TAGLIO 59 KG.



MP35A
TRONCHESE
PREZZO: € 283,85
POTENZA DI TAGLIO 450 KG.

MR30A
TRONCHESE
PREZZO: € 179,50
ESISTE ANCHE AUTOMATICO



MR3A
MINITRONCHESE
PREZZO: € 188,47
POTENZA DI TAGLIO 59 KG.

● PER SISTEMI AUTOMATICI



MP35AM
TRONCHESE CON CORPO CILINDRICO DA MONTARE SU SUPPORTO
PREZZO: € 251,54
POTENZA DI TAGLIO 230 KG.

**NUMEROSI MODELLI
DISPONIBILI IN STOCK**
Consultateci

Caratteristiche e prezzi delle lame a richiesta

Griglie magnetiche -15%!

Griglie magnetiche

Da installare all'interno della tramoggia.
Non necessita di essere fissata.
Qualità molto elevata.

Fabbricata in acciaio inox.

Due modelli :

Griglie per tramogge quadrate

Griglie per tramogge tonde



Griglie per tramogge quadrate

Griglie per tramogge tonde

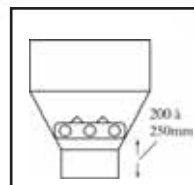

Dimensioni (mm)	Griglie Quadrate Ref.	Prezzo in euro	-15%
100	CHM10	78,44	70,59
150	CHM15	147,26	132,54
200	CHM20	208,09	187,28
250	CHM25	232,10	208,89
300	CHM30	312,14	280,93
350	CHM35	352,16	316,94

Griglie Tonde Ref.	Prezzo in euro	-15%
-	-	-
RHM15	136,06	122,45
RHM20	176,07	158,47
RHM25	211,29	190,16
RHM30	264,12	237,71
RHM35	312,14	280,93

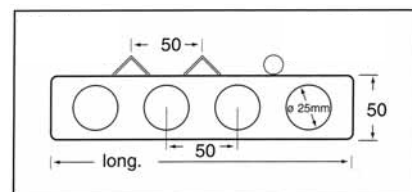

Prodotti di spurgo

- CORATEX** : emulsione di spurgo 28,97 €
43432 : PDQ - Super purge 26,50 €
ABP25 : granuli di spurgo in acrilico 70,00 €



Agenti distaccanti

Gamma premium

42612N : Distaccanti universali 8,05 €
 Senza silicone. Utilizzo fino a 320°C.
 Compatibilità: vernici, metallizzazione o serigrafia.

45712N : Pure eze non silconico 4,85 €
 Senza silicone. Utilizzo fino a 315°C.
 Idoneo per applicazioni medicali o alimentari. Recuperabile

41612N : Economico 3,90 €
 Contiene silicone. Utilizzo fino a 320°C.
 Approvato per applicazioni alimentari.



Gamma economica

MR375 : Distaccante a film secco 5,80 €
 9% di silicone. Molto efficace fino a 260°C.
 Recuperabile. Asciuga rapidamente, forma un film anti-aderente.

MR325 : Agente distaccante recuperabile senza silicone 4,90 €
 Senza silicone. Utilizzo fino a 200°C.
 Recuperabile, film secco ultra fine. Ideale per stampi caldi.

Spray antiruggine/Anti-

MR679 : Spray antiruggine 4,00 €
 Pellicola semi-flessibile duratura, no peeling. Ideale per stoccaggio di stampi in esterno.

42914 : Spray barriera 4,10 €
 Senza silicone. Neutralizza le impronte digitali, spray extra secco non penetra negli elementi mobili.

MR415 : Detergente e sgrassante 5,35 €
 Sopprime e scioglie olii, grassi e altri residui. Pulisce bene senza necessità di asciugare.

MR417 : Lubrificante anti-grippaggio 3,85 €
 Sottilissimo film di olio antiruggine. Ideale per combattere l'umidità nei circuiti elettrici.

43916T : Grasso per alte temperature 7,50 €
 Senza silicone. Per applicazioni medicali, o alimentari.

Puntali vite

Puntali vite

Per la fabbricazione dei puntali sono utilizzati i migliori materiali, e un'attenzione particolare è posta alla progettazione di ogni componente.

Una gamma molto estesa di puntali, anelli e sedi :

- Alta resistenza: la scelta degli acciai e dei trattamenti (Nitrurazione, trattamento con stellite o cromo duro per i materiali fluorati) garantiscono condizioni d'impiego ottimali.
- Designi specifici: materiali carichi, ad alta viscosità per ottenere eccellenti performance (fluidità, cicli di iniezione brevi).
- Referenze costruttori :
sostituzione, scambio di standard dei puntali vite, sedi e anelli per le vostre presse di marca e tipo diversi.

TIPO A - STANDARD NITRURATO

TIPO E - BI-METALLICO

PER TUTTI I TIPI DI PRESSA:

ANKERWERKE	FANUC FERROMATIC	NISSEI
ARBURG	FORTUNE	OIMA
AUSTIN ALLEN	GOLDSTAR	PECO
BARDEZ DASSETT	JOSEPH KRAUSS	PENTAJECT
BATTENFELD	JSW	PLASTIJET
BILLION	KAP	REIFFENHAUSER
BIPEL	KAWAGUCHI	RUCKER
BM BIRAGHI	KLOCKNER / FERROMATIC	SANDRETTO
BONE CRAVEN	KLOCKNER / WINDSOR	SHIBAURA
BOY	KRAUSS MAFFEI	SHINWA SEIKL
BUHLER	KRUPPS	STORK
CHAUN LIH FA	KUASY	STUBBE
CHEN HSONG	METTALMEC	SUMITOMO
CINCINNATI	MIR	TOSHIBA
DEMAG	MITSUBISHI	TOYO
DK	NEGRI BOSSI	TRIULZI
DONG SHIN	NETSTAL	VAN DORN
ENGEL	NEW BRITAIN	WINDSOR
FAHR BUCHER	NIIGATA	

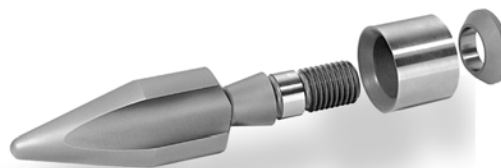

Puntale



Puntale ad alta

Puntali a

■ IDEALI PER MATERIALI CONVENZIONALI, poliolefine, stirenici... POCO SENSIBILI AL CALORE, O VISCOSI

■ MANUTENZIONE FACILE E A BASSO COSTO

■ OTTIMO FLUSSO DEL MATERIALE, concezione easy-flow



Mettetevi in contatto con noi

Viti e cilindri di plastificazione

Concezione e fabbricazione dei vostri sistemi di iniezione, estrusione, estrusione soffiaggio. Tutti i materiali termoplastici ed elastomeri. Forniamo viti standard costruttore, ma concepiamo anche o miglioriamo le vostre viti, barriera, miscelatori, doppio filetto, a settori,...

UNA GAMMA ECCEZIONALE

Sistemi nuovi

● **Viti nitrurate** : specialmente concepite per applicazioni d'ordine generale con materiali non abrasivi. Immerse in un bagno di nitrurazione per oltre 72 ore che garantisce una nitrurazione profonda di altissima qualità. Durata dell'ordine di 1000/1100 HV). Lo spessore è di 0.5mm. Queste viti sono rigenerabili successivamente.

● **Viti nitrurate con deposito di Stellite G12** : identiche alle precedenti, ricevono in più un trattamento di Stellite sui capi dei filetti. Di durata eccezionale, questo trattamento permette di migliorare in maniera molto sensibile la durata del vostro sistema vite. Queste viti sono rigenerabili successivamente.

● **Viti temperate** : fabbricate con acciai speciali che dopo il trattamento permettono di conservare una eccellente durata al cuore stesso della barra. (62Hrc). Gamme differenti sono disponibili al fine di rispondere al meglio alle esigenze di resistenza all'usura all'abrasione, alla corrosione, agli agenti antifiamma,...

Non esitate a contattare il nostro servizio tecnico per avere maggiori delucidazioni in merito.

● **Viti al carburo di Tungsteno** : per le condizioni estreme, una gamma specifica che offre i migliori risultati in termini di resistenza.

● **Cilindri nitrurati** : specialmente concepiti per le applicazioni di ordine generale con materiali non abrasivi. Immersi in un bagno di nitrurazione per una durata di oltre 72 ore per garantire una nitrurazione profonda di grande qualità, con una durata è di 1000/1100 HV). Il loro spessore è nell'ordine di 0.5mm. Queste cilindri sono rigenerabili successivamente.

● **Cilindri bimetallici** : i nostri progetti provengono dai migliori esperti di metallurgia per le materie plastiche e ci rifiutiamo di transigere su questo punto. Tutti i nostri sistemi vite/cilindro anti-usura, anti-abrasione (60/62Hrc) hanno cicli di vita che superano da 3 a 4 volte i cilindri convenzionali.

Sono sempre accompagnati da un certificato relativo ai materiali e alle dimensioni. Senza dubbio la migliore qualità sul mercato in questo momento. Per ogni applicazione vi consiglieremo sul tipo di progetto da scegliere dalla semplice fornitura bimetallica fino al Carburo di Tungsteno, il più resistente.

Rigenerazioni

Ridate una seconda vita al vostro sistema vite/cilindro :

Diverse soluzioni sono attualmente disponibili seguendo i tassi d'usura constatati, il grado d'urgenza o, più semplicemente i costi preventivati.

● **Riparazione viti** : usate, e danneggiate su qualche filetto in seguito all'introduzione di corpi estranei, le viti sono generalmente riparabili. Dopo una analisi diagnostica completa realizziamo un'apporto di metallo ad alta resistenza, quindi riportiamo ai livelli originali. Dopo il trattamento (nitrurazione) viene effettuato un apporto di stellite finalizzato

a donare ancora maggiore resistenza. La vostra vite dispone di una seconda vita ad un costo largamente inferiore a quello di una vite nuova.

● **Riparazione di cilindri**: sono disponibili diverse tecniche.

- **Rialesaggio ad un livello superiore** : la vite in questo caso deve essere portata al nuovo livello.
- **Rigenerazione per inserzione di una camicia parziale**: ricostruzione del rivestimento della parte anteriore del cilindro con inserzione di una camicia nitrurata bimetallica.
- **Rigenerazione per inserzione di una camicia su tutta la lunghezza** : camicia bimetallica, o semplicemente nitrurata, questa soluzione offre il vantaggio di ripartire con un cilindro nuovo, ma anche di potere ricominciare l'operazione ulteriormente.

Una analisi diagnostica viene sistematicamente effettuata su ogni vite, cilindro o testa del cilindro. Vi verrà comunicato un rendiconto con il costo esatto del nostro intervento.

Non dimenticate che i nostri tecnici sono disponibili a realizzare direttamente presso i vostri impianti tutte le verifiche d'usura e le misurazioni.



Sistemi di presa

Componenti di presa



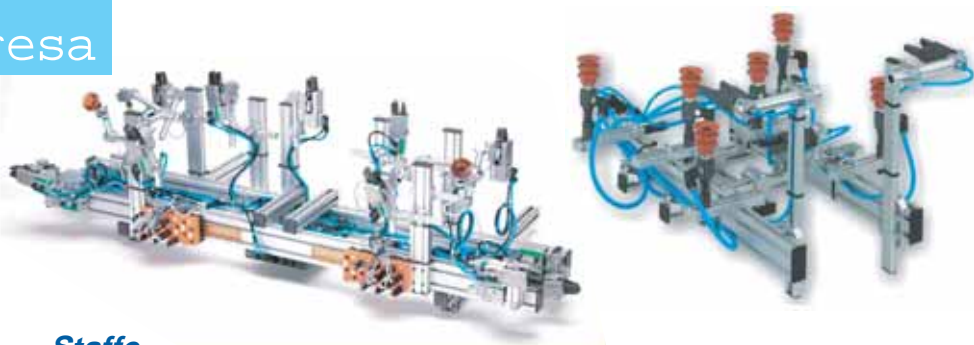

per manipolatori robotizzati

GLI ELEMENTI IN KIT

I componenti nelle immagini di queste pagine si combinano gli uni con gli altri e sono forniti con i profili di fissaggio e/o altri elementi di raccordo. In questo modo, tutti i pezzi possono essere utilizzati e montati immediatamente. Le possibilità di combinazioni sono infinite ed adattabili a tutte le applicazioni immaginabili. Il montaggio molto semplice di questi componenti vi fa risparmiare tempo e denaro dal momento che voi stessi vi costruite la vostra mano di presa. Grazie alla loro modularità e al fatto che ogni componente possa essere riutilizzato, potete riutilizzare questi componenti per un'altra mano.



Staffe

 <p>Eckverbindebrücke Corner Joint Plates Connecteurs en coin</p> <table border="1"> <thead> <tr> <th>Art. No.</th> <th>C</th> <th>D</th> </tr> </thead> <tbody> <tr> <td>GR01.000</td> <td>20</td> <td>20</td> </tr> <tr> <td>GR01.001</td> <td>30</td> <td>40</td> </tr> </tbody> </table>	Art. No.	C	D	GR01.000	20	20	GR01.001	30	40	 <p>Schwenkverbindebrücke Corner Joint Plates Connecteurs en coin</p> <table border="1"> <thead> <tr> <th>Art. No.</th> <th>C</th> </tr> </thead> <tbody> <tr> <td>GR01.002</td> <td>30</td> </tr> </tbody> </table>	Art. No.	C	GR01.002	30	 <p>Winkel-Klemmstücke, starr Angle Clamps, rigid brides angulaires, fixes</p> <table border="1"> <thead> <tr> <th>Art. No.</th> <th>A</th> <th>B</th> <th>C</th> <th>L</th> </tr> </thead> <tbody> <tr> <td>GR02.001</td> <td>10</td> <td>16</td> <td>16</td> <td>40</td> </tr> <tr> <td>GR02.002</td> <td>15</td> <td>20</td> <td>20</td> <td>50</td> </tr> <tr> <td>GR02.003</td> <td>20</td> <td>25</td> <td>25</td> <td>55</td> </tr> </tbody> </table>	Art. No.	A	B	C	L	GR02.001	10	16	16	40	GR02.002	15	20	20	50	GR02.003	20	25	25	55	 <p>Winkel-Klemmstück, verstellbar Angle Clamps, adjustable brides angulaires, ajustables</p> <table border="1"> <thead> <tr> <th>Art. No.</th> <th>A</th> <th>B</th> <th>C</th> <th>D</th> <th>L</th> </tr> </thead> <tbody> <tr> <td>GR02.010</td> <td>10</td> <td>16</td> <td>16</td> <td>42</td> <td>82</td> </tr> <tr> <td>GR02.011</td> <td>14</td> <td>20</td> <td>18</td> <td>32</td> <td>90</td> </tr> <tr> <td>GR02.012</td> <td>15</td> <td>20</td> <td>18</td> <td>32</td> <td>96</td> </tr> <tr> <td>GR02.013</td> <td>20</td> <td>20</td> <td>21</td> <td>33</td> <td>102</td> </tr> </tbody> </table>	Art. No.	A	B	C	D	L	GR02.010	10	16	16	42	82	GR02.011	14	20	18	32	90	GR02.012	15	20	18	32	96	GR02.013	20	20	21	33	102	 <p>Winkel-Klemmstück, seitliche Montage Angle Clamps, lateral mounting brides angulaires, montage latéral</p> <table border="1"> <thead> <tr> <th>Art. No.</th> <th>A</th> <th>B</th> <th>C</th> <th>D</th> </tr> </thead> <tbody> <tr> <td>GR03.020</td> <td>10</td> <td>30</td> <td>14</td> <td>6,5</td> </tr> <tr> <td>GR03.021</td> <td>15</td> <td>35</td> <td>19</td> <td>8,5</td> </tr> <tr> <td>GR03.022</td> <td>20</td> <td>40</td> <td>24</td> <td>12,5</td> </tr> </tbody> </table>	Art. No.	A	B	C	D	GR03.020	10	30	14	6,5	GR03.021	15	35	19	8,5	GR03.022	20	40	24	12,5
Art. No.	C	D																																																																																					
GR01.000	20	20																																																																																					
GR01.001	30	40																																																																																					
Art. No.	C																																																																																						
GR01.002	30																																																																																						
Art. No.	A	B	C	L																																																																																			
GR02.001	10	16	16	40																																																																																			
GR02.002	15	20	20	50																																																																																			
GR02.003	20	25	25	55																																																																																			
Art. No.	A	B	C	D	L																																																																																		
GR02.010	10	16	16	42	82																																																																																		
GR02.011	14	20	18	32	90																																																																																		
GR02.012	15	20	18	32	96																																																																																		
GR02.013	20	20	21	33	102																																																																																		
Art. No.	A	B	C	D																																																																																			
GR03.020	10	30	14	6,5																																																																																			
GR03.021	15	35	19	8,5																																																																																			
GR03.022	20	40	24	12,5																																																																																			

Bracci di presa

 <p>Bracci di presa, fissi</p> <table border="1"> <thead> <tr> <th>Art. No.</th> <th>M</th> <th>A</th> <th>B</th> <th>C</th> <th>D</th> <th>E</th> <th>F</th> <th>G</th> </tr> </thead> <tbody> <tr> <td>GR03.001</td> <td>10</td> <td>16</td> <td>16</td> <td>16</td> <td>16</td> <td>16</td> <td>16</td> <td>16</td> </tr> <tr> <td>GR03.002</td> <td>15</td> <td>20</td> <td>20</td> <td>20</td> <td>20</td> <td>20</td> <td>20</td> <td>20</td> </tr> <tr> <td>GR03.003</td> <td>20</td> <td>25</td> <td>25</td> <td>25</td> <td>25</td> <td>25</td> <td>25</td> <td>25</td> </tr> <tr> <td>GR03.004</td> <td>25</td> <td>30</td> <td>30</td> <td>30</td> <td>30</td> <td>30</td> <td>30</td> <td>30</td> </tr> <tr> <td>GR03.005</td> <td>30</td> <td>35</td> <td>35</td> <td>35</td> <td>35</td> <td>35</td> <td>35</td> <td>35</td> </tr> <tr> <td>GR03.006</td> <td>35</td> <td>40</td> <td>40</td> <td>40</td> <td>40</td> <td>40</td> <td>40</td> <td>40</td> </tr> <tr> <td>GR03.007</td> <td>40</td> <td>45</td> <td>45</td> <td>45</td> <td>45</td> <td>45</td> <td>45</td> <td>45</td> </tr> <tr> <td>GR03.008</td> <td>45</td> <td>50</td> <td>50</td> <td>50</td> <td>50</td> <td>50</td> <td>50</td> <td>50</td> </tr> <tr> <td>GR03.009</td> <td>50</td> <td>55</td> <td>55</td> <td>55</td> <td>55</td> <td>55</td> <td>55</td> <td>55</td> </tr> <tr> <td>GR03.010</td> <td>55</td> <td>60</td> <td>60</td> <td>60</td> <td>60</td> <td>60</td> <td>60</td> <td>60</td> </tr> <tr> <td>GR03.011</td> <td>60</td> <td>65</td> <td>65</td> <td>65</td> <td>65</td> <td>65</td> <td>65</td> <td>65</td> </tr> <tr> <td>GR03.012</td> <td>65</td> <td>70</td> <td>70</td> <td>70</td> <td>70</td> <td>70</td> <td>70</td> <td>70</td> </tr> <tr> <td>GR03.013</td> <td>70</td> <td>75</td> <td>75</td> <td>75</td> <td>75</td> <td>75</td> <td>75</td> <td>75</td> </tr> <tr> <td>GR03.014</td> <td>75</td> <td>80</td> <td>80</td> <td>80</td> <td>80</td> <td>80</td> <td>80</td> <td>80</td> </tr> <tr> <td>GR03.015</td> <td>80</td> <td>85</td> <td>85</td> <td>85</td> <td>85</td> <td>85</td> <td>85</td> <td>85</td> </tr> <tr> <td>GR03.016</td> <td>85</td> <td>90</td> <td>90</td> <td>90</td> <td>90</td> <td>90</td> <td>90</td> <td>90</td> </tr> <tr> <td>GR03.017</td> <td>90</td> <td>95</td> <td>95</td> <td>95</td> <td>95</td> <td>95</td> <td>95</td> <td>95</td> </tr> <tr> <td>GR03.018</td> <td>95</td> <td>100</td> <td>100</td> <td>100</td> <td>100</td> <td>100</td> <td>100</td> <td>100</td> </tr> <tr> <td>GR03.019</td> <td>100</td> <td>105</td> <td>105</td> <td>105</td> <td>105</td> <td>105</td> <td>105</td> <td>105</td> </tr> <tr> <td>GR03.020</td> <td>105</td> <td>110</td> <td>110</td> <td>110</td> <td>110</td> <td>110</td> <td>110</td> <td>110</td> </tr> <tr> <td>GR03.021</td> <td>110</td> <td>115</td> <td>115</td> <td>115</td> <td>115</td> <td>115</td> <td>115</td> <td>115</td> </tr> <tr> <td>GR03.022</td> <td>115</td> <td>120</td> <td>120</td> <td>120</td> <td>120</td> <td>120</td> <td>120</td> <td>120</td> </tr> <tr> <td>GR03.023</td> <td>120</td> <td>125</td> <td>125</td> <td>125</td> <td>125</td> <td>125</td> <td>125</td> <td>125</td> </tr> <tr> <td>GR03.024</td> <td>125</td> <td>130</td> <td>130</td> <td>130</td> <td>130</td> <td>130</td> <td>130</td> <td>130</td> </tr> <tr> <td>GR03.025</td> <td>130</td> <td>135</td> <td>135</td> <td>135</td> <td>135</td> <td>135</td> <td>135</td> <td>135</td> </tr> <tr> <td>GR03.026</td> <td>135</td> <td>140</td> <td>140</td> <td>140</td> <td>140</td> <td>140</td> <td>140</td> <td>140</td> </tr> <tr> <td>GR03.027</td> <td>140</td> <td>145</td> <td>145</td> <td>145</td> <td>145</td> <td>145</td> <td>145</td> <td>145</td> </tr> <tr> <td>GR03.028</td> <td>145</td> <td>150</td> <td>150</td> <td>150</td> <td>150</td> <td>150</td> <td>150</td> <td>150</td> </tr> <tr> <td>GR03.029</td> <td>150</td> <td>155</td> <td>155</td> <td>155</td> <td>155</td> <td>155</td> <td>155</td> <td>155</td> </tr> <tr> <td>GR03.030</td> <td>155</td> <td>160</td> <td>160</td> <td>160</td> <td>160</td> <td>160</td> <td>160</td> <td>160</td> </tr> <tr> <td>GR03.031</td> <td>160</td> <td>165</td> <td>165</td> <td>165</td> <td>165</td> <td>165</td> <td>165</td> <td>165</td> </tr> <tr> <td>GR03.032</td> <td>165</td> <td>170</td> <td>170</td> <td>170</td> <td>170</td> <td>170</td> <td>170</td> <td>170</td> </tr> <tr> <td>GR03.033</td> <td>170</td> <td>175</td> <td>175</td> <td>175</td> <td>175</td> <td>175</td> <td>175</td> <td>175</td> </tr> <tr> <td>GR03.034</td> <td>175</td> <td>180</td> <td>180</td> <td>180</td> <td>180</td> <td>180</td> <td>180</td> <td>180</td> </tr> <tr> <td>GR03.035</td> <td>180</td> <td>185</td> <td>185</td> <td>185</td> <td>185</td> <td>185</td> <td>185</td> <td>185</td> </tr> </tbody> </table>	Art. No.	M	A	B	C	D	E	F	G	GR03.001	10	16	16	16	16	16	16	16	GR03.002	15	20	20	20	20	20	20	20	GR03.003	20	25	25	25	25	25	25	25	GR03.004	25	30	30	30	30	30	30	30	GR03.005	30	35	35	35	35	35	35	35	GR03.006	35	40	40	40	40	40	40	40	GR03.007	40	45	45	45	45	45	45	45	GR03.008	45	50	50	50	50	50	50	50	GR03.009	50	55	55	55	55	55	55	55	GR03.010	55	60	60	60	60	60	60	60	GR03.011	60	65	65	65	65	65	65	65	GR03.012	65	70	70	70	70	70	70	70	GR03.013	70	75	75	75	75	75	75	75	GR03.014	75	80	80	80	80	80	80	80	GR03.015	80	85	85	85	85	85	85	85	GR03.016	85	90	90	90	90	90	90	90	GR03.017	90	95	95	95	95	95	95	95	GR03.018	95	100	100	100	100	100	100	100	GR03.019	100	105	105	105	105	105	105	105	GR03.020	105	110	110	110	110	110	110	110	GR03.021	110	115	115	115	115	115	115	115	GR03.022	115	120	120	120	120	120	120	120	GR03.023	120	125	125	125	125	125	125	125	GR03.024	125	130	130	130	130	130	130	130	GR03.025	130	135	135	135	135	135	135	135	GR03.026	135	140	140	140	140	140	140	140	GR03.027	140	145	145	145	145	145	145	145	GR03.028	145	150	150	150	150	150	150	150	GR03.029	150	155	155	155	155	155	155	155	GR03.030	155	160	160	160	160	160	160	160	GR03.031	160	165	165	165	165	165	165	165	GR03.032	165	170	170	170	170	170	170	170	GR03.033	170	175	175	175	175	175	175	175	GR03.034	175	180	180	180	180	180	180	180	GR03.035	180	185	185	185	185	185	185	185	 <p>Bracci di presa, fissi</p> <table border="1"> <thead> <tr> <th>Art. No.</th> <th>M</th> <th>A</th> <th>B</th> <th>C</th> <th>D</th> <th>E</th> <th>F</th> <th>G</th> </tr> </thead> <tbody> <tr> <td>GR03.036</td> <td>10</td> <td>16</td> <td>16</td> <td>16</td> <td>16</td> <td>16</td> <td>16</td> <td>16</td> </tr> <tr> <td>GR03.037</td> <td>15</td> <td>20</td> <td>20</td> <td>20</td> <td>20</td> <td>20</td> <td>20</td> <td>20</td> </tr> <tr> <td>GR03.038</td> <td>20</td> <td>25</td> <td>25</td> <td>25</td> <td>25</td> <td>25</td> <td>25</td> <td>25</td> </tr> <tr> <td>GR03.039</td> <td>25</td> <td>30</td> <td>30</td> <td>30</td> <td>30</td> <td>30</td> <td>30</td> <td>30</td> </tr> <tr> <td>GR03.040</td> <td>30</td> <td>35</td> <td>35</td> <td>35</td> <td>35</td> <td>35</td> <td>35</td> <td>35</td> </tr> <tr> <td>GR03.041</td> <td>35</td> <td>40</td> <td>40</td> <td>40</td> <td>40</td> <td>40</td> <td>40</td> <td>40</td> </tr> <tr> <td>GR03.042</td> <td>40</td> <td>45</td> <td>45</td> <td>45</td> <td>45</td> <td>45</td> <td>45</td> <td>45</td> </tr> <tr> <td>GR03.043</td> <td>45</td> <td>50</td> <td>50</td> <td>50</td> <td>50</td> <td>50</td> <td>50</td> <td>50</td> </tr> <tr> <td>GR03.044</td> <td>50</td> <td>55</td> <td>55</td> <td>55</td> <td>55</td> <td>55</td> <td>55</td> <td>55</td> </tr> <tr> <td>GR03.045</td> <td>55</td> <td>60</td> <td>60</td> <td>60</td> <td>60</td> <td>60</td> <td>60</td> <td>60</td> </tr> <tr> <td>GR03.046</td> <td>60</td> <td>65</td> <td>65</td> <td>65</td> <td>65</td> <td>65</td> <td>65</td> <td>65</td> </tr> <tr> <td>GR03.047</td> <td>65</td> <td>70</td> <td>70</td> <td>70</td> <td>70</td> <td>70</td> <td>70</td> <td>70</td> </tr> <tr> <td>GR03.048</td> <td>70</td> <td>75</td> <td>75</td> <td>75</td> <td>75</td> <td>75</td> <td>75</td> <td>75</td> </tr> <tr> <td>GR03.049</td> <td>75</td> <td>80</td> <td>80</td> <td>80</td> <td>80</td> <td>80</td> <td>80</td> <td>80</td> </tr> <tr> <td>GR03.050</td> <td>80</td> <td>85</td> <td>85</td> <td>85</td> <td>85</td> <td>85</td> <td>85</td> <td>85</td> </tr> <tr> <td>GR03.051</td> <td>85</td> <td>90</td> <td>90</td> <td>90</td> <td>90</td> <td>90</td> <td>90</td> <td>90</td> </tr> <tr> <td>GR03.052</td> <td>90</td> <td>95</td> <td>95</td> <td>95</td> <td>95</td> <td>95</td> <td>95</td> <td>95</td> </tr> <tr> <td>GR03.053</td> <td>95</td> <td>100</td> <td>100</td> <td>100</td> <td>100</td> <td>100</td> <td>100</td> <td>100</td> </tr> <tr> <td>GR03.054</td> <td>100</td> <td>105</td> <td>105</td> <td>105</td> <td>105</td> <td>105</td> <td>105</td> <td>105</td> </tr> <tr> <td>GR03.055</td> <td>105</td> <td>110</td> <td>110</td> <td>110</td> <td>110</td> <td>110</td> <td>110</td> <td>110</td> </tr> <tr> <td>GR03.056</td> <td>110</td> <td>115</td> <td>115</td> <td>115</td> <td>115</td> <td>115</td> <td>115</td> <td>115</td> </tr> <tr> <td>GR03.057</td> <td>115</td> <td>120</td> <td>120</td> <td>120</td> <td>120</td> <td>120</td> <td>120</td> <td>120</td> </tr> <tr> <td>GR03.058</td> <td>120</td> <td>125</td> <td>125</td> <td>125</td> <td>125</td> <td>125</td> <td>125</td> <td>125</td> </tr> <tr> <td>GR03.059</td> <td>125</td> <td>130</td> <td>130</td> <td>130</td> <td>130</td> <td>130</td> <td>130</td> <td>130</td> </tr> <tr> <td>GR03.060</td> <td>130</td> <td>135</td> <td>135</td> <td>135</td> <td>135</td> <td>135</td> <td>135</td> <td>135</td> </tr> <tr> <td>GR03.061</td> <td>135</td> <td>140</td> <td>140</td> <td>140</td> <td>140</td> <td>140</td> <td>140</td> <td>140</td> </tr> <tr> <td>GR03.062</td> <td>140</td> <td>145</td> <td>145</td> <td>145</td> <td>145</td> <td>145</td> <td>145</td> <td>145</td> </tr> <tr> <td>GR03.063</td> <td>145</td> <td>150</td> <td>150</td> <td>150</td> <td>150</td> <td>150</td> <td>150</td> <td>150</td> </tr> <tr> <td>GR03.064</td> <td>150</td> <td>155</td> <td>155</td> <td>155</td> <td>155</td> <td>155</td> <td>155</td> <td>155</td> </tr> <tr> <td>GR03.065</td> <td>155</td> <td>160</td> <td>160</td> <td>160</td> <td>160</td> <td>160</td> <td>160</td> <td>160</td> </tr> <tr> <td>GR03.066</td> <td>160</td> <td>165</td> <td>165</td> <td>165</td> <td>165</td> <td>165</td> <td>165</td> <td>165</td> </tr> <tr> <td>GR03.067</td> <td>165</td> <td>170</td> <td>170</td> <td>170</td> <td>170</td> <td>170</td> <td>170</td> <td>170</td> </tr> <tr> <td>GR03.068</td> <td>170</td> <td>175</td> <td>175</td> <td>175</td> <td>175</td> <td>175</td> <td>175</td> <td>175</td> </tr> <tr> <td>GR03.069</td> <td>175</td> <td>180</td> <td>180</td> <td>180</td> <td>180</td> <td>180</td> <td>180</td> <td>180</td> </tr> <tr> <td>GR03.070</td> <td>180</td> <td>185</td> <td>185</td> <td>185</td> <td>185</td> <td>185</td> <td>185</td> <td>185</td> </tr> <tr> <td>GR03.071</td> <td>185</td> <td>190</td> <td>190</td> <td>190</td> <td>190</td> <td>190</td> <td>190</td> <td>190</td> </tr> <tr> <td>GR03.072</td> <td>190</td> <td>195</td> <td>195</td> <td>195</td> <td>195</td> <td>195</td> <td>195</td> <td>195</td> </tr> <tr> <td>GR03.073</td> <td>195</td> <td>200</td> <td>200</td> <td>200</td> <td>200</td> <td>200</td> <td>200</td> <td>200</td> </tr> <tr> <td>GR03.074</td> <td>200</td> <td>205</td> <td>205</td> <td>205</td> <td>205</td> <td>205</td> <td>205</td> <td>205</td> </tr> <tr> <td>GR03.075</td> <td>205</td> <td>210</td> <td>210</td> <td>210</td> <td>210</td> <td>210</td> <td>210</td> <td>210</td> </tr> </tbody> </table>	Art. No.	M	A	B	C	D	E	F	G	GR03.036	10	16	16	16	16	16	16	16	GR03.037	15	20	20	20	20	20	20	20	GR03.038	20	25	25	25	25	25	25	25	GR03.039	25	30	30	30	30	30	30	30	GR03.040	30	35	35	35	35	35	35	35	GR03.041	35	40	40	40	40	40	40	40	GR03.042	40	45	45	45	45	45	45	45	GR03.043	45	50	50	50	50	50	50	50	GR03.044	50	55	55	55	55	55	55	55	GR03.045	55	60	60	60	60	60	60	60	GR03.046	60	65	65	65	65	65	65	65	GR03.047	65	70	70	70	70	70	70	70	GR03.048	70	75	75	75	75	75	75	75	GR03.049	75	80	80	80	80	80	80	80	GR03.050	80	85	85	85	85	85	85	85	GR03.051	85	90	90	90	90	90	90	90	GR03.052	90	95	95	95	95	95	95	95	GR03.053	95	100	100	100	100	100	100	100	GR03.054	100	105	105	105	105	105	105	105	GR03.055	105	110	110	110	110	110	110	110	GR03.056	110	115	115	115	115	115	115	115	GR03.057	115	120	120	120	120	120	120	120	GR03.058	120	125	125	125	125	125	125	125	GR03.059	125	130	130	130	130	130	130	130	GR03.060	130	135	135	135	135	135	135	135	GR03.061	135	140	140	140	140	140	140	140	GR03.062	140	145	145	145	145	145	145	145	GR03.063	145	150	150	150	150	150	150	150	GR03.064	150	155	155	155	155	155	155	155	GR03.065	155	160	160	160	160	160	160	160	GR03.066	160	165	165	165	165	165	165	165	GR03.067	165	170	170	170	170	170	170	170	GR03.068	170	175	175	175	175	175	175	175	GR03.069	175	180	180	180	180	180	180	180	GR03.070	180	185	185	185	185	185	185	185	GR03.071	185	190	190	190	190	190	190	190	GR03.072	190	195	195	195	195	195	195	195	GR03.073	195	200	200	200	200	200	200	200	GR03.074	200	205	205	205	205	205	205	205	GR03.075	205	210	210	210	210	210	210	210	 <p>Bracci di presa, regolabili</p> <table border="1"> <thead> <tr> <th>Art. No.</th> <th>M</th> <th>A</th> <th>B</th> <th>C</th> <th>D</th> <th>E</th> <th>F</th> <th>G</th> </tr> </thead> <tbody> <tr> <td>GR03.076</td> <td>10</td> <td>16</td> <td>16</td> <td>16</td> <td>16</td> <td>16</td> <td>16</td> <td>16</td> </tr> <tr> <td>GR03.077</td> <td>15</td> <td>20</td> <td>20</td> <td>20</td> <td>20</td> <td>20</td> <td>20</td> <td>20</td> </tr> <tr> <td>GR03.078</td> <td>20</td> <td>25</td> <td>25</td> <td>25</td> <td>25</td> <td>25</td> <td>25</td> <td>25</td> </tr> <tr> <td>GR03.079</td> <td>25</td> <td>30</td> <td>30</td> <td>30</td> <td>30</td> <td>30</td> <td>30</td> <td>30</td> </tr> <tr> <td>GR03.080</td> <td>30</td> <td>35</td> <td>35</td> <td>35</td> <td>35</td> <td>35</td> <td>35</td> <td>35</td> </tr> <tr> <td>GR03.081</td> <td>35</td> <td>40</td> <td>40</td> <td>40</td> <td>40</td> <td>40</td> <td>40</td> <td>40</td> </tr> <tr> <td>GR03.082</td> <td>40</td> <td>45</td> <td>45</td> <td>45</td> <td>45</td> <td>45</td> <td>45</td> <td>45</td> </tr> <tr> <td>GR03.083</td> <td>45</td> <td>50</td> <td>50</td> <td>50</td> <td>50</td> <td>50</td> <td>50</td> <td>50</td> </tr> <tr> <td>GR03.084</td> <td>50</td> <td>55</td> <td>55</td> <td>55</td> <td>55</td> <td>55</td> <td>55</td> <td>55</td> </tr> <tr> <td>GR03.085</td> <td>55</td> <td>60</td> <td>60</td> <td>60</td> <td>60</td> <td>60</td> <td>60</td> <td>60</td> </tr> <tr> <td>GR03.086</td> <td>60</td> <td>65</td> <td>65</td> <td>65</td> <td>65</td> <td>65</td> <td>65</td> <td>65</td> </tr> <tr> <td>GR03.087</td> <td>65</td> <td>70</td> <td>70</td> <td>70</td> <td>70</td> <td>70</td> <td>70</td> <td>70</td> </tr> <tr> <td>GR03.088</td> <td>70</td> <td>75</td> <td>75</td> <td>75</td> <td>75</td> <td>75</td> <td>75</td> <td>75</td> </tr> <tr> <td>GR03.089</td> <td>75</td> <td>80</td> <td>80</td> <td>80</td> <td>80</td> <td>80</td> <td>80</td> <td>80</td> </tr> <tr> <td>GR03.090</td> <td>80</td> <td>85</td> <td>85</td> <td>85</td> <td>85</td> <td>85</td> <td>85</td> <td>85</td> </tr> <tr> <td>GR03.091</td> <td>85</td> <td>90</td> <td>90</td> <td>90</td> <td>90</td> <td>90</td> <td>90</td> <td>90</td> </tr> <tr> <td>GR03.092</td> <td>90</td> <td>95</td> <td>95</td> <td>95</td> <td>95</td> <td>95</td> <td>95</td> <td>95</td> </tr> <tr> <td>GR03.093</td> <td>95</td> <td>100</td> <td>100</td> <td>100</td> <td>100</td> <td>100</td> <td>100</td> <td>100</td> </tr> <tr> <td>GR03.094</td> <td>100</td> <td>105</td> <td>105</td> <td>105</td> <td>105</td> <td>105</td> <td>105</td> <td>105</td> </tr> <tr> <td>GR03.095</td> <td>105</td> <td>110</td> <td>110</td> <td>110</td> <td>110</td> <td>110</td> <td>110</td> <td>110</td> </tr> <tr> <td>GR03.096</td> <td>110</td> <td>115</td> <td>115</td> <td>115</td> <td>115</td> <td>115</td> <td>115</td> <td>115</td> </tr> <tr> <td>GR03.097</td> <td>115</td> <td>120</td> <td>120</td> <td>120</td> <td>120</td> <td>120</td> <td>120</td> <td>120</td> </tr> <tr> <td>GR03.098</td> <td>120</td> <td>125</td> <td>125</td> <td>125</td> <td>125</td> <td>125</td> <td>125</td> <td>125</td> </tr> <tr> <td>GR03.099</td> <td>125</td> <td>130</td> <td>130</td> <td>130</td> <td>130</td> <td>130</td> <td>130</td> <td>130</td> </tr> <tr> <td>GR03.100</td> <td>130</td> <td>135</td> <td>135</td> <td>135</td> <td>135</td> <td>135</td> <td>135</td> <td>135</td> </tr> <tr> <td>GR03.101</td> <td>135</td> <td>140</td> <td>140</td> <td>140</td> <td>140</td> <td>140</td> <td>140</td> <td>140</td> </tr> <tr> <td>GR03.102</td> <td>140</td> <td>145</td> <td>145</td> <td>145</td> <td>145</td> <td>145</td> <td>145</td> <td>145</td> </tr> <tr> <td>GR03.103</td> <td>145</td> <td>150</td> <td>150</td> <td>150</td> <td>150</td> <td>150</td> <td>150</td> <td>150</td> </tr> <tr> <td>GR03.104</td> <td>150</td> <td>155</td> <td>155</td> <td>155</td> <td>155</td> <td>155</td> <td>155</td> <td>155</td> </tr> <tr> <td>GR03.105</td> <td>155</td> <td>160</td> <td>160</td> <td>160</td> <td>160</td> <td>160</td> <td>160</td> <td>160</td> </tr> <tr> <td>GR03.106</td> <td>160</td> <td>165</td> <td>165</td> <td>165</td> <td>165</td> <td>165</td> <td>165</td> <td>165</td> </tr> <tr> <td>GR03.107</td> <td>165</td> <td>170</td> <td>170</td> <td>170</td> <td>170</td> <td>170</td> <td>170</td> <td>170</td> </tr> <tr> <td>GR03.108</td> <td>170</td> <td>175</td> <td>175</td> <td>175</td> <td>175</td> <td>175</td> <td>175</td> <td>175</td> </tr> <tr> <td>GR03.109</td> <td>175</td> <td>180</td> <td>180</td> <td>180</td> <td>180</td> <td>180</td> <td>180</td> <td>180</td> </tr> <tr> <td>GR03.110</td> <td>180</td> <td>185</td> <td>185</td> <td>185</td> <td>185</td> <td>185</td> <td>185</td> <td>185</td> </tr> <tr> <td>GR03.111</td> <td>185</td> <td>190</td> <td>190</td> <td>190</td> <td>190</td> <td>190</td> <td>190</td> <td>190</td> </tr> <tr> <td>GR03.112</td> <td>190</td> <td>195</td> <td>195</td> <td>195</td> <td>195</td> <td>195</td> <td>195</td> <td>195</td> </tr> <tr> <td>GR03.113</td> <td>195</td> <td>200</td> <td>200</td> <td>200</td> <td>200</td> <td>200</td> <td>200</td> <td>200</td> </tr> </tbody> </table>	Art. No.	M	A	B	C	D	E	F	G	GR03.076	10	16	16	16	16	16	16	16	GR03.077	15	20	20	20	20	20	20	20	GR03.078	20	25	25	25	25	25	25	25	GR03.079	25	30	30	30	30	30	30	30	GR03.080	30	35	35	35	35	35	35	35	GR03.081	35	40	40	40	40	40	40	40	GR03.082	40	45	45	45	45	45	45	45	GR03.083	45	50	50	50	50	50	50	50	GR03.084	50	55	55	55	55	55	55	55	GR03.085	55	60	60	60	60	60	60	60	GR03.086	60	65	65	65	65	65	65	65	GR03.087	65	70	70	70	70	70	70	70	GR03.088	70	75	75	75	75	75	75	75	GR03.089	75	80	80	80	80	80	80	80	GR03.090	80	85	85	85	85	85	85	85	GR03.091	85	90	90	90	90	90	90	90	GR03.092	90	95	95	95	95	95	95	95	GR03.093	95	100	100	100	100	100	100	100	GR03.094	100	105	105	105	105	105	105	105	GR03.095	105	110	110	110	110	110	110	110	GR03.096	110	115	115	115	115	115	115	115	GR03.097	115	120	120	120	120	120	120	120	GR03.098	120	125	125	125	125	125	125	125	GR03.099	125	130	130	130	130	130	130	130	GR03.100	130	135	135	135	135	135	135	135	GR03.101	135	140	140	140	140	140	140	140	GR03.102	140	145	145	145	145	145	145	145	GR03.103	145	150	150	150	150	150	150	150	GR03.104	150	155	155	155	155	155	155	155	GR03.105	155	160	160	160	160	160	160	160	GR03.106	160	165	165	165	165	165	165	165	GR03.107	165	170	170	170	170	170	170	170	GR03.108	170	175	175	175	175	175	175	175	GR03.109	175	180	180	180	180	180	180	180	GR03.110	180	185	185	185	185	185	185	185	GR03.111	185	190	190	190	190	190	190	190	GR03.112	190	195	195	195	195	195	195	195	GR03.113	195	200	200	200	200	200	200	200	 <p>Bracci di presa, regolabili</p> <table border="1"> <thead> <tr> <th>Art. No.</th> <th>M</th> </tr></thead></table>	Art. No.	M
Art. No.	M	A	B	C	D	E	F	G																																																																																																																																																																																																																																																																																																																																																																																																																																																																																																																																																																																																																																																																																																																																																																																																																																																																																																																																																																																																																																																																																	
GR03.001	10	16	16	16	16	16	16	16																																																																																																																																																																																																																																																																																																																																																																																																																																																																																																																																																																																																																																																																																																																																																																																																																																																																																																																																																																																																																																																																																	
GR03.002	15	20	20	20	20	20	20	20																																																																																																																																																																																																																																																																																																																																																																																																																																																																																																																																																																																																																																																																																																																																																																																																																																																																																																																																																																																																																																																																																	
GR03.003	20	25	25	25	25	25	25	25																																																																																																																																																																																																																																																																																																																																																																																																																																																																																																																																																																																																																																																																																																																																																																																																																																																																																																																																																																																																																																																																																	
GR03.004	25	30	30	30	30	30	30	30																																																																																																																																																																																																																																																																																																																																																																																																																																																																																																																																																																																																																																																																																																																																																																																																																																																																																																																																																																																																																																																																																	
GR03.005	30	35	35	35	35	35	35	35																																																																																																																																																																																																																																																																																																																																																																																																																																																																																																																																																																																																																																																																																																																																																																																																																																																																																																																																																																																																																																																																																	
GR03.006	35	40	40	40	40	40	40	40																																																																																																																																																																																																																																																																																																																																																																																																																																																																																																																																																																																																																																																																																																																																																																																																																																																																																																																																																																																																																																																																																	
GR03.007	40	45	45	45	45	45	45	45																																																																																																																																																																																																																																																																																																																																																																																																																																																																																																																																																																																																																																																																																																																																																																																																																																																																																																																																																																																																																																																																																	
GR03.008	45	50	50	50	50	50	50	50																																																																																																																																																																																																																																																																																																																																																																																																																																																																																																																																																																																																																																																																																																																																																																																																																																																																																																																																																																																																																																																																																	
GR03.009	50	55	55	55	55	55	55	55																																																																																																																																																																																																																																																																																																																																																																																																																																																																																																																																																																																																																																																																																																																																																																																																																																																																																																																																																																																																																																																																																	
GR03.010	55	60	60	60	60	60	60	60																																																																																																																																																																																																																																																																																																																																																																																																																																																																																																																																																																																																																																																																																																																																																																																																																																																																																																																																																																																																																																																																																	
GR03.011	60	65	65	65	65	65	65	65																																																																																																																																																																																																																																																																																																																																																																																																																																																																																																																																																																																																																																																																																																																																																																																																																																																																																																																																																																																																																																																																																	
GR03.012	65	70	70	70	70	70	70	70																																																																																																																																																																																																																																																																																																																																																																																																																																																																																																																																																																																																																																																																																																																																																																																																																																																																																																																																																																																																																																																																																	
GR03.013	70	75	75	75	75	75	75	75																																																																																																																																																																																																																																																																																																																																																																																																																																																																																																																																																																																																																																																																																																																																																																																																																																																																																																																																																																																																																																																																																	
GR03.014	75	80	80	80	80	80	80	80																																																																																																																																																																																																																																																																																																																																																																																																																																																																																																																																																																																																																																																																																																																																																																																																																																																																																																																																																																																																																																																																																	
GR03.015	80	85	85	85	85	85	85	85																																																																																																																																																																																																																																																																																																																																																																																																																																																																																																																																																																																																																																																																																																																																																																																																																																																																																																																																																																																																																																																																																	
GR03.016	85	90	90	90	90	90	90	90																																																																																																																																																																																																																																																																																																																																																																																																																																																																																																																																																																																																																																																																																																																																																																																																																																																																																																																																																																																																																																																																																	
GR03.017	90	95	95	95	95	95	95	95																																																																																																																																																																																																																																																																																																																																																																																																																																																																																																																																																																																																																																																																																																																																																																																																																																																																																																																																																																																																																																																																																	
GR03.018	95	100	100	100	100	100	100	100																																																																																																																																																																																																																																																																																																																																																																																																																																																																																																																																																																																																																																																																																																																																																																																																																																																																																																																																																																																																																																																																																	
GR03.019	100	105	105	105	105	105	105	105																																																																																																																																																																																																																																																																																																																																																																																																																																																																																																																																																																																																																																																																																																																																																																																																																																																																																																																																																																																																																																																																																	
GR03.020	105	110	110	110	110	110	110	110																																																																																																																																																																																																																																																																																																																																																																																																																																																																																																																																																																																																																																																																																																																																																																																																																																																																																																																																																																																																																																																																																	
GR03.021	110	115	115	115	115	115	115	115																																																																																																																																																																																																																																																																																																																																																																																																																																																																																																																																																																																																																																																																																																																																																																																																																																																																																																																																																																																																																																																																																	
GR03.022	115	120	120	120	120	120	120	120																																																																																																																																																																																																																																																																																																																																																																																																																																																																																																																																																																																																																																																																																																																																																																																																																																																																																																																																																																																																																																																																																	
GR03.023	120	125	125	125	125	125	125	125																																																																																																																																																																																																																																																																																																																																																																																																																																																																																																																																																																																																																																																																																																																																																																																																																																																																																																																																																																																																																																																																																	
GR03.024	125	130	130	130	130	130	130	130																																																																																																																																																																																																																																																																																																																																																																																																																																																																																																																																																																																																																																																																																																																																																																																																																																																																																																																																																																																																																																																																																	
GR03.025	130	135	135	135	135	135	135	135																																																																																																																																																																																																																																																																																																																																																																																																																																																																																																																																																																																																																																																																																																																																																																																																																																																																																																																																																																																																																																																																																	
GR03.026	135	140	140	140	140	140	140	140																																																																																																																																																																																																																																																																																																																																																																																																																																																																																																																																																																																																																																																																																																																																																																																																																																																																																																																																																																																																																																																																																	
GR03.027	140	145	145	145	145	145	145	145																																																																																																																																																																																																																																																																																																																																																																																																																																																																																																																																																																																																																																																																																																																																																																																																																																																																																																																																																																																																																																																																																	
GR03.028	145	150	150	150	150	150	150	150																																																																																																																																																																																																																																																																																																																																																																																																																																																																																																																																																																																																																																																																																																																																																																																																																																																																																																																																																																																																																																																																																	
GR03.029	150	155	155	155	155	155	155	155																																																																																																																																																																																																																																																																																																																																																																																																																																																																																																																																																																																																																																																																																																																																																																																																																																																																																																																																																																																																																																																																																	
GR03.030	155	160	160	160	160	160	160	160																																																																																																																																																																																																																																																																																																																																																																																																																																																																																																																																																																																																																																																																																																																																																																																																																																																																																																																																																																																																																																																																																	
GR03.031	160	165	165	165	165	165	165	165																																																																																																																																																																																																																																																																																																																																																																																																																																																																																																																																																																																																																																																																																																																																																																																																																																																																																																																																																																																																																																																																																	
GR03.032	165	170	170	170	170	170	170	170																																																																																																																																																																																																																																																																																																																																																																																																																																																																																																																																																																																																																																																																																																																																																																																																																																																																																																																																																																																																																																																																																	
GR03.033	170	175	175	175	175	175	175	175																																																																																																																																																																																																																																																																																																																																																																																																																																																																																																																																																																																																																																																																																																																																																																																																																																																																																																																																																																																																																																																																																	
GR03.034	175	180	180	180	180	180	180	180																																																																																																																																																																																																																																																																																																																																																																																																																																																																																																																																																																																																																																																																																																																																																																																																																																																																																																																																																																																																																																																																																	
GR03.035	180	185	185	185	185	185	185	185																																																																																																																																																																																																																																																																																																																																																																																																																																																																																																																																																																																																																																																																																																																																																																																																																																																																																																																																																																																																																																																																																	
Art. No.	M	A	B	C	D	E	F	G																																																																																																																																																																																																																																																																																																																																																																																																																																																																																																																																																																																																																																																																																																																																																																																																																																																																																																																																																																																																																																																																																	
GR03.036	10	16	16	16	16	16	16	16																																																																																																																																																																																																																																																																																																																																																																																																																																																																																																																																																																																																																																																																																																																																																																																																																																																																																																																																																																																																																																																																																	
GR03.037	15	20	20	20	20	20	20	20																																																																																																																																																																																																																																																																																																																																																																																																																																																																																																																																																																																																																																																																																																																																																																																																																																																																																																																																																																																																																																																																																	
GR03.038	20	25	25	25	25	25	25	25																																																																																																																																																																																																																																																																																																																																																																																																																																																																																																																																																																																																																																																																																																																																																																																																																																																																																																																																																																																																																																																																																	
GR03.039	25	30	30	30	30	30	30	30																																																																																																																																																																																																																																																																																																																																																																																																																																																																																																																																																																																																																																																																																																																																																																																																																																																																																																																																																																																																																																																																																	
GR03.040	30	35	35	35	35	35	35	35																																																																																																																																																																																																																																																																																																																																																																																																																																																																																																																																																																																																																																																																																																																																																																																																																																																																																																																																																																																																																																																																																	
GR03.041	35	40	40	40	40	40	40	40																																																																																																																																																																																																																																																																																																																																																																																																																																																																																																																																																																																																																																																																																																																																																																																																																																																																																																																																																																																																																																																																																	
GR03.042	40	45	45	45	45	45	45	45																																																																																																																																																																																																																																																																																																																																																																																																																																																																																																																																																																																																																																																																																																																																																																																																																																																																																																																																																																																																																																																																																	
GR03.043	45	50	50	50	50	50	50	50																																																																																																																																																																																																																																																																																																																																																																																																																																																																																																																																																																																																																																																																																																																																																																																																																																																																																																																																																																																																																																																																																	
GR03.044	50	55	55	55	55	55	55	55																																																																																																																																																																																																																																																																																																																																																																																																																																																																																																																																																																																																																																																																																																																																																																																																																																																																																																																																																																																																																																																																																	
GR03.045	55	60	60	60	60	60	60	60																																																																																																																																																																																																																																																																																																																																																																																																																																																																																																																																																																																																																																																																																																																																																																																																																																																																																																																																																																																																																																																																																	
GR03.046	60	65	65	65	65	65	65	65																																																																																																																																																																																																																																																																																																																																																																																																																																																																																																																																																																																																																																																																																																																																																																																																																																																																																																																																																																																																																																																																																	
GR03.047	65	70	70	70	70	70	70	70																																																																																																																																																																																																																																																																																																																																																																																																																																																																																																																																																																																																																																																																																																																																																																																																																																																																																																																																																																																																																																																																																	
GR03.048	70	75	75	75	75	75	75	75																																																																																																																																																																																																																																																																																																																																																																																																																																																																																																																																																																																																																																																																																																																																																																																																																																																																																																																																																																																																																																																																																	
GR03.049	75	80	80	80	80	80	80	80																																																																																																																																																																																																																																																																																																																																																																																																																																																																																																																																																																																																																																																																																																																																																																																																																																																																																																																																																																																																																																																																																	
GR03.050	80	85	85	85	85	85	85	85																																																																																																																																																																																																																																																																																																																																																																																																																																																																																																																																																																																																																																																																																																																																																																																																																																																																																																																																																																																																																																																																																	
GR03.051	85	90	90	90	90	90	90	90																																																																																																																																																																																																																																																																																																																																																																																																																																																																																																																																																																																																																																																																																																																																																																																																																																																																																																																																																																																																																																																																																	
GR03.052	90	95	95	95	95	95	95	95																																																																																																																																																																																																																																																																																																																																																																																																																																																																																																																																																																																																																																																																																																																																																																																																																																																																																																																																																																																																																																																																																	
GR03.053	95	100	100	100	100	100	100	100																																																																																																																																																																																																																																																																																																																																																																																																																																																																																																																																																																																																																																																																																																																																																																																																																																																																																																																																																																																																																																																																																	
GR03.054	100	105	105	105	105	105	105	105																																																																																																																																																																																																																																																																																																																																																																																																																																																																																																																																																																																																																																																																																																																																																																																																																																																																																																																																																																																																																																																																																	
GR03.055	105	110	110	110	110	110	110	110																																																																																																																																																																																																																																																																																																																																																																																																																																																																																																																																																																																																																																																																																																																																																																																																																																																																																																																																																																																																																																																																																	
GR03.056	110	115	115	115	115	115	115	115																																																																																																																																																																																																																																																																																																																																																																																																																																																																																																																																																																																																																																																																																																																																																																																																																																																																																																																																																																																																																																																																																	
GR03.057	115	120	120	120	120	120	120	120																																																																																																																																																																																																																																																																																																																																																																																																																																																																																																																																																																																																																																																																																																																																																																																																																																																																																																																																																																																																																																																																																	
GR03.058	120	125	125	125	125	125	125	125																																																																																																																																																																																																																																																																																																																																																																																																																																																																																																																																																																																																																																																																																																																																																																																																																																																																																																																																																																																																																																																																																	
GR03.059	125	130	130	130	130	130	130	130																																																																																																																																																																																																																																																																																																																																																																																																																																																																																																																																																																																																																																																																																																																																																																																																																																																																																																																																																																																																																																																																																	
GR03.060	130	135	135	135	135	135	135	135																																																																																																																																																																																																																																																																																																																																																																																																																																																																																																																																																																																																																																																																																																																																																																																																																																																																																																																																																																																																																																																																																	
GR03.061	135	140	140	140	140	140	140	140																																																																																																																																																																																																																																																																																																																																																																																																																																																																																																																																																																																																																																																																																																																																																																																																																																																																																																																																																																																																																																																																																	
GR03.062	140	145	145	145	145	145	145	145																																																																																																																																																																																																																																																																																																																																																																																																																																																																																																																																																																																																																																																																																																																																																																																																																																																																																																																																																																																																																																																																																	
GR03.063	145	150	150	150	150	150	150	150																																																																																																																																																																																																																																																																																																																																																																																																																																																																																																																																																																																																																																																																																																																																																																																																																																																																																																																																																																																																																																																																																	
GR03.064	150	155	155	155	155	155	155	155																																																																																																																																																																																																																																																																																																																																																																																																																																																																																																																																																																																																																																																																																																																																																																																																																																																																																																																																																																																																																																																																																	
GR03.065	155	160	160	160	160	160	160	160																																																																																																																																																																																																																																																																																																																																																																																																																																																																																																																																																																																																																																																																																																																																																																																																																																																																																																																																																																																																																																																																																	
GR03.066	160	165	165	165	165	165	165	165																																																																																																																																																																																																																																																																																																																																																																																																																																																																																																																																																																																																																																																																																																																																																																																																																																																																																																																																																																																																																																																																																	
GR03.067	165	170	170	170	170	170	170	170																																																																																																																																																																																																																																																																																																																																																																																																																																																																																																																																																																																																																																																																																																																																																																																																																																																																																																																																																																																																																																																																																	
GR03.068	170	175	175	175	175	175	175	175																																																																																																																																																																																																																																																																																																																																																																																																																																																																																																																																																																																																																																																																																																																																																																																																																																																																																																																																																																																																																																																																																	
GR03.069	175	180	180	180	180	180	180	180																																																																																																																																																																																																																																																																																																																																																																																																																																																																																																																																																																																																																																																																																																																																																																																																																																																																																																																																																																																																																																																																																	
GR03.070	180	185	185	185	185	185	185	185																																																																																																																																																																																																																																																																																																																																																																																																																																																																																																																																																																																																																																																																																																																																																																																																																																																																																																																																																																																																																																																																																	
GR03.071	185	190	190	190	190	190	190	190																																																																																																																																																																																																																																																																																																																																																																																																																																																																																																																																																																																																																																																																																																																																																																																																																																																																																																																																																																																																																																																																																	
GR03.072	190	195	195	195	195	195	195	195																																																																																																																																																																																																																																																																																																																																																																																																																																																																																																																																																																																																																																																																																																																																																																																																																																																																																																																																																																																																																																																																																	
GR03.073	195	200	200	200	200	200	200	200																																																																																																																																																																																																																																																																																																																																																																																																																																																																																																																																																																																																																																																																																																																																																																																																																																																																																																																																																																																																																																																																																	
GR03.074	200	205	205	205	205	205	205	205																																																																																																																																																																																																																																																																																																																																																																																																																																																																																																																																																																																																																																																																																																																																																																																																																																																																																																																																																																																																																																																																																	
GR03.075	205	210	210	210	210	210	210	210																																																																																																																																																																																																																																																																																																																																																																																																																																																																																																																																																																																																																																																																																																																																																																																																																																																																																																																																																																																																																																																																																	
Art. No.	M	A	B	C	D	E	F	G																																																																																																																																																																																																																																																																																																																																																																																																																																																																																																																																																																																																																																																																																																																																																																																																																																																																																																																																																																																																																																																																																	
GR03.076	10	16	16	16	16	16	16	16																																																																																																																																																																																																																																																																																																																																																																																																																																																																																																																																																																																																																																																																																																																																																																																																																																																																																																																																																																																																																																																																																	
GR03.077	15	20	20	20	20	20	20	20																																																																																																																																																																																																																																																																																																																																																																																																																																																																																																																																																																																																																																																																																																																																																																																																																																																																																																																																																																																																																																																																																	
GR03.078	20	25	25	25	25	25	25	25																																																																																																																																																																																																																																																																																																																																																																																																																																																																																																																																																																																																																																																																																																																																																																																																																																																																																																																																																																																																																																																																																	
GR03.079	25	30	30	30	30	30	30	30																																																																																																																																																																																																																																																																																																																																																																																																																																																																																																																																																																																																																																																																																																																																																																																																																																																																																																																																																																																																																																																																																	
GR03.080	30	35	35	35	35	35	35	35																																																																																																																																																																																																																																																																																																																																																																																																																																																																																																																																																																																																																																																																																																																																																																																																																																																																																																																																																																																																																																																																																	
GR03.081	35	40	40	40	40	40	40	40																																																																																																																																																																																																																																																																																																																																																																																																																																																																																																																																																																																																																																																																																																																																																																																																																																																																																																																																																																																																																																																																																	
GR03.082	40	45	45	45	45	45	45	45																																																																																																																																																																																																																																																																																																																																																																																																																																																																																																																																																																																																																																																																																																																																																																																																																																																																																																																																																																																																																																																																																	
GR03.083	45	50	50	50	50	50	50	50																																																																																																																																																																																																																																																																																																																																																																																																																																																																																																																																																																																																																																																																																																																																																																																																																																																																																																																																																																																																																																																																																	
GR03.084	50	55	55	55	55	55	55	55																																																																																																																																																																																																																																																																																																																																																																																																																																																																																																																																																																																																																																																																																																																																																																																																																																																																																																																																																																																																																																																																																	
GR03.085	55	60	60	60	60	60	60	60																																																																																																																																																																																																																																																																																																																																																																																																																																																																																																																																																																																																																																																																																																																																																																																																																																																																																																																																																																																																																																																																																	
GR03.086	60	65	65	65	65	65	65	65																																																																																																																																																																																																																																																																																																																																																																																																																																																																																																																																																																																																																																																																																																																																																																																																																																																																																																																																																																																																																																																																																	
GR03.087	65	70	70	70	70	70	70	70																																																																																																																																																																																																																																																																																																																																																																																																																																																																																																																																																																																																																																																																																																																																																																																																																																																																																																																																																																																																																																																																																	
GR03.088	70	75	75	75	75	75	75	75																																																																																																																																																																																																																																																																																																																																																																																																																																																																																																																																																																																																																																																																																																																																																																																																																																																																																																																																																																																																																																																																																	
GR03.089	75	80	80	80	80	80	80	80																																																																																																																																																																																																																																																																																																																																																																																																																																																																																																																																																																																																																																																																																																																																																																																																																																																																																																																																																																																																																																																																																	
GR03.090	80	85	85	85	85	85	85	85																																																																																																																																																																																																																																																																																																																																																																																																																																																																																																																																																																																																																																																																																																																																																																																																																																																																																																																																																																																																																																																																																	
GR03.091	85	90	90	90	90	90	90	90																																																																																																																																																																																																																																																																																																																																																																																																																																																																																																																																																																																																																																																																																																																																																																																																																																																																																																																																																																																																																																																																																	
GR03.092	90	95	95	95	95	95	95	95																																																																																																																																																																																																																																																																																																																																																																																																																																																																																																																																																																																																																																																																																																																																																																																																																																																																																																																																																																																																																																																																																	
GR03.093	95	100	100	100	100	100	100	100																																																																																																																																																																																																																																																																																																																																																																																																																																																																																																																																																																																																																																																																																																																																																																																																																																																																																																																																																																																																																																																																																	
GR03.094	100	105	105	105	105	105	105	105																																																																																																																																																																																																																																																																																																																																																																																																																																																																																																																																																																																																																																																																																																																																																																																																																																																																																																																																																																																																																																																																																	
GR03.095	105	110	110	110	110	110	110	110																																																																																																																																																																																																																																																																																																																																																																																																																																																																																																																																																																																																																																																																																																																																																																																																																																																																																																																																																																																																																																																																																	
GR03.096	110	115	115	115	115	115	115	115																																																																																																																																																																																																																																																																																																																																																																																																																																																																																																																																																																																																																																																																																																																																																																																																																																																																																																																																																																																																																																																																																	
GR03.097	115	120	120	120	120	120	120	120																																																																																																																																																																																																																																																																																																																																																																																																																																																																																																																																																																																																																																																																																																																																																																																																																																																																																																																																																																																																																																																																																	
GR03.098	120	125	125	125	125	125	125	125																																																																																																																																																																																																																																																																																																																																																																																																																																																																																																																																																																																																																																																																																																																																																																																																																																																																																																																																																																																																																																																																																	
GR03.099	125	130	130	130	130	130	130	130																																																																																																																																																																																																																																																																																																																																																																																																																																																																																																																																																																																																																																																																																																																																																																																																																																																																																																																																																																																																																																																																																	
GR03.100	130	135	135	135	135	135	135	135																																																																																																																																																																																																																																																																																																																																																																																																																																																																																																																																																																																																																																																																																																																																																																																																																																																																																																																																																																																																																																																																																	
GR03.101	135	140	140	140	140	140	140	140																																																																																																																																																																																																																																																																																																																																																																																																																																																																																																																																																																																																																																																																																																																																																																																																																																																																																																																																																																																																																																																																																	
GR03.102	140	145	145	145	145	145	145	145																																																																																																																																																																																																																																																																																																																																																																																																																																																																																																																																																																																																																																																																																																																																																																																																																																																																																																																																																																																																																																																																																	
GR03.103	145	150	150	150	150	150	150	150																																																																																																																																																																																																																																																																																																																																																																																																																																																																																																																																																																																																																																																																																																																																																																																																																																																																																																																																																																																																																																																																																	
GR03.104	150	155	155	155	155	155	155	155																																																																																																																																																																																																																																																																																																																																																																																																																																																																																																																																																																																																																																																																																																																																																																																																																																																																																																																																																																																																																																																																																	
GR03.105	155	160	160	160	160	160	160	160																																																																																																																																																																																																																																																																																																																																																																																																																																																																																																																																																																																																																																																																																																																																																																																																																																																																																																																																																																																																																																																																																	
GR03.106	160	165	165	165	165	165	165	165																																																																																																																																																																																																																																																																																																																																																																																																																																																																																																																																																																																																																																																																																																																																																																																																																																																																																																																																																																																																																																																																																	
GR03.107	165	170	170	170	170	170	170	170																																																																																																																																																																																																																																																																																																																																																																																																																																																																																																																																																																																																																																																																																																																																																																																																																																																																																																																																																																																																																																																																																	
GR03.108	170	175	175	175	175	175	175	175																																																																																																																																																																																																																																																																																																																																																																																																																																																																																																																																																																																																																																																																																																																																																																																																																																																																																																																																																																																																																																																																																	
GR03.109	175	180	180	180	180	180	180	180																																																																																																																																																																																																																																																																																																																																																																																																																																																																																																																																																																																																																																																																																																																																																																																																																																																																																																																																																																																																																																																																																	
GR03.110	180	185	185	185	185	185	185	185																																																																																																																																																																																																																																																																																																																																																																																																																																																																																																																																																																																																																																																																																																																																																																																																																																																																																																																																																																																																																																																																																	
GR03.111	185	190	190	190	190	190	190	190																																																																																																																																																																																																																																																																																																																																																																																																																																																																																																																																																																																																																																																																																																																																																																																																																																																																																																																																																																																																																																																																																	
GR03.112	190	195	195	195	195	195	195	195																																																																																																																																																																																																																																																																																																																																																																																																																																																																																																																																																																																																																																																																																																																																																																																																																																																																																																																																																																																																																																																																																	
GR03.113	195	200	200	200	200	200	200	200																																																																																																																																																																																																																																																																																																																																																																																																																																																																																																																																																																																																																																																																																																																																																																																																																																																																																																																																																																																																																																																																																	
Art. No.	M																																																																																																																																																																																																																																																																																																																																																																																																																																																																																																																																																																																																																																																																																																																																																																																																																																																																																																																																																																																																																																																																																								

Sistemi di presa

COSTRUITE VOI STESSI LA VOSTRA MANO DI PRESA

Profili

GR01.001	GR01.002	GR01.003	GR01.004	GR01.005	GR01.006	GR01.007
Longueur 2000 mm		Longueur 2000 mm			Longueur 2000 mm	

Embout

Art. No.	A	B
GR01.010	18	20
GR01.011	18	40
GR01.012	20	20
GR01.013	20	40
GR01.014	20	60
GR01.015	28	80
GR01.016	40	40

Anglet

Art. No.	A	B
GR01.030	20	20
GR01.051	40	40

Art. No. A B	Art. No. A B	Art. No. A B	Art. No. A B
GR01.020 20 20	GR01.030 19 20	GR01.021 30 40	GR01.040 20 30
GR01.021 20 40	GR01.031 20 40	GR01.022 30 40	GR01.041 20 20
GR01.022 40 40	GR01.032 30 25		GR01.042 40 20

Rail de fixation avec rotule

Art. No.	A	B	C
GR01.070	12	-	M 4
GR01.071	12	-	M 5

Art. No.	A	B	C
GR01.080*	30	9	M 4
GR01.081	20	10	M 5
GR01.082	25	12	M 5
GR01.083	30	20	M 3
GR01.084	33	25	M 3
GR01.085	40	30	M 3
GR01.086	40	50	M 3

Art. No.	A	B	C
GR01.090*	30	9	M 4
GR01.091	20	10	M 3
GR01.092	25	12	M 5
GR01.093	30	20	M 5
GR01.094	33	25	M 3
GR01.095	40	30	M 3
GR01.096	40	50	M 3
GR01.097**	12	-	M 3
GR01.098*	20	-	M 5

* ohne Kugel / without spring ball / senza rotule

Ventose per vuoto

La nostra gamma di ventose per vuoto si declina in oltre 20.000 varianti.

Non esitate a richiedere la documentazione relativa alle ventose per vuoto.



Pinze di presa

Ø 10 mm

22 N

Pinces de préhension, simple effet

Art. No.	Ø A	B1	F	D	H
GR04.100	10	33	80	20	M 5

Ø 10 mm

22 N

Pinces de préhension, simple effet

Art. No.	Ø A	B1	F	G	H
GR04.101	10	33	80	20	M 5

Ø 10 mm

20 N

Pinces de préhension, double effet

Art. No.	Ø A	B1	F	G	H
GR04.102	10	33	80	23	M 5

Ø 20 mm

50 N

Pinces de préhension, simple effet avec mâchoire

mâchoire demeurée

Art. No.	Ø A	B	F	G	H
GR04.120A	20	30	130	17	M 5

Ø 20 mm

50 N

Pinces de préhension, simple effet avec mâchoire

mâchoire pour prise de carottes en bois

Art. No.	Ø A	B	F	G	H
GR04.120B	20	30	130	15	M 5

Ø 20 mm

50 N

Pinces de préhension, simple effet avec mâchoire

pour mâchoire personnalisée

Art. No.	Ø A	B	F	H
GR04.120C	20	30	94	M 5

Ø 20 mm

50 N

Pinces de préhension, simple effet avec mâchoire

mâchoire demeurée

Art. No.	Ø A	B	F	H
GR04.120D	20	34	122	M 5

Pinces parallèles

Art. No.	A	B	C	E	H
GR04.114	37	34	17,8	19	10
GR04.115	46	43	21,8	24	12
GR04.116	56	51	25,8	28	16

Pinces angulaires

Art. No.	A	B	C	H
GS-10	30	57	16	18,7
GS-16	40	67	24	24,7
GS-20	50	85	28	32,0
GS-25	64	103	34	38,8

Pinzes per taglio pneumatiche

Art. No.	Ø A	B	Pressione di taglio	Cilindrata per tagliatura
*GT-NR10L	36	113	388 N	max. Ø 4
*GT-NR20	45	129	1372 N	max. Ø 7
*GT-NR50	56	145	2744 N	max. Ø 10
*GT-NR50	75	222	4704 N	max. Ø 13

Art. No.	Ø A	B	H	E+H
GT-NR10LH	36	45	110	
GT-NR20H	45	52	120	
GT-NR30H	56	65	130	
GT-NR50H	75	85	150	

*Includi: Seix de lames au choix - pour toute application (se reporter au catalogue spécifique "pinces pneumatiques cou pointes".

Sistema di staffe rapido

Sistema di staffe rapido 1-40	Sistema di staffe rapido 1-100	Sistema di staffe rapido 1-160	Sistema di staffe rapido 1-200	Sistema di staffe rapido
Art. No. A B	Art. No. A B	Art. No. A B	Art. No. A B	Art. No. Ø D1 Ø D2
GR00.001 20 40	GR00.002 40 100	GR00.003 70 160	GR00.004 100 200	GR00 40 50

Accessori

Accessori 1	Accessori 2	Accessori 3	Accessori 4	Accessori 5	Accessori 6
Art. No. Ø A Ø B	Art. No. Ø A Ø B	Art. No. Ø A Ø B	Art. No. Ø A Ø B	Art. No. Ø A Ø B	Art. No. Ø A Ø B
GR00.001 20 40	GR00.002 40 100	GR00.003 70 160	GR00.004 100 200	GR00.005 40 50	GR00.006 40 50

Appoggio interno

Art. No.	31.009*	31.005*	31.008*	31.007*	31.006*
ØD1	17	20	27	37	47
ØD2	25	28	40	50	65
Ød1	18,5	18,5	27	39	49
d1	M 10	M 10	M 12	M 16	M 20
H	102	101	119	120	124
h	51	50	63	60	61
X	0,5 bar	0,5 bar	2,0 bar	2,0 bar	2,0 bar

D1 = D + 40% max.
X = pressione max.

*Materiale: NR (max. +85° C) o Vulkollan (max. +90° C)

Appoggio esterno

Art. No.	1319	1320	1321	1322	1323	1324	1325	1326
ØA	5-15	10-25	15-35	20-45	5-15	10-25	15-35	20-45
ØC	19	40	37	70	19	27	37	48
D	36	48	52	56	36	48	52	56

* per pezzi de Ø esteriur

Toutes dimensions en mm

Ugelli speciali

Ugelli a riscaldamento

La soluzione ideale per tutte le applicazioni ad alta temperatura con ugello immerso.

Concepito per un utilizzo su attrezzature (o altre applicazioni) sui quali le dimensioni degli interassi non sono sufficienti a consentire l'impiego di resistenze tradizionali come le resistenze a fascia ...



Ugelli a riscaldamento interno

Nuova concezione di ugello a riscaldamento interno con una resistenza formabile spiralata. Fornisce potenze e temperature importanti che migliorano le condizioni di stampaggio con materie plastiche che si stampano a temperature elevate.

Particolarmente adattato per le ricevute di ugello in ritiro.



Ugelli miscelatori

Ugelli ad alto potere di miscelazione (tipo SMN).

Nuova generazione di ugelli miscelatori su cui può essere montato un filtro specifico della serie SM. I filtri utilizzati con o senza elementi modulari di miscelazione proteggono i vostri blocchi in caso di utilizzo di macinati trattenendo le particelle solide.

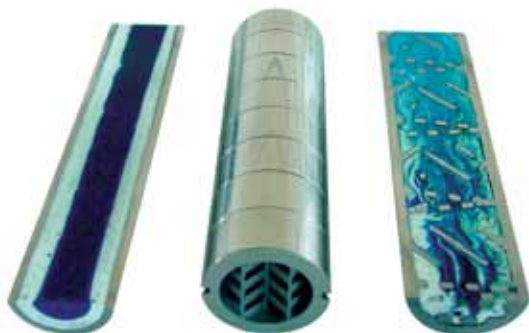

TIPO	VISCOSITA'		DIAMETRO VITE mm
	BASSA cm ³ /s	ALTA cm ³ /s	
SMN-12-8	300	200	20 - 50
SMN-18-8	1000	700	40 - 75
SMN-22-8	1800	1200	50 - 90
SMN-27-8	3400	2300	70 - 120
SMN-33-8	6200	4000	80 - 140
SMN-40-8	11000	7400	100 - 180

Ugelli miscelatori a elementi

Ugelli di grandi dimensioni di nuova generazione

A partire da solo € 372,30 !

I vantaggi di un ugello miscelatore sono numerosi. I più significativi? Certamente i risparmi effettuati nell'uso di coloranti secchi o sui concentrati (circa 10-20%), oltre alle riduzioni dei tempi ciclo.



TIPO	DIAMETRO ELEMENTI	VISCOSITA'		
		BASSA PA - PP PEBD cm ³ /s	MEDIA PS - PP cm ³ /s	ALTA PEHD - ABS - PP chargé cm ³ /s
A et B	16	80	40	25
C et D	21	190	85	60,0
E et F	25	370	170	110
G	32	780	350	230
H	40	1550	700	460
I	48	2800	1200	800
J	60	5100	2300	1600
K	75	9900	4500	3000

Ugelli speciali

Ugelli filtranti

FILTRI A DISCO:

Per tutte le marche di presse a iniezione.

Questi ugelli filtranti di nuova generazione per particolari metallici hanno un potere di filtrazione elevato e sono disponibili a stock per permettervi di stampare senza perdere tempo. Utilizzate gli adattatori standard per adattarli alla vostra macchina. Ugelli standard con filettatura 1 - 3/4"-8. Finale normale di ricambio.

FILTRI A PASSAGGIO FORZATO:

Questi nuovi filtri a passaggio forzato sono concepiti a partire da un foro cieco all'interno del quale viene direttamente spinto il materiale, quindi di un secondo disposto all'inverso e che permette al materiale di penetrare nello stampo. Un passaggio di 0,38 mm tra il \varnothing interno dell'ugello e il diametro esterno dell'inserto assicura un'azione filtrante impedendo che le particelle inquinanti penetrino all'interno dello stampo...

Disponibile anche il rivestimento in titanio.

FILTRI SMF PER MATERIALI RIMACINATI:

Proteggono i canali caldi in caso di utilizzo di materiali macinati. Trattengono le contaminazioni solide (per esempio particelle metalliche) e gli infusi.

Adattabilità possibile senza modifica del corpo dell'ugello.



Disco filtrante TMF40



Piccoli adattatori di ugelli

Questi adattatori permettono di utilizzare finali standard GP, NRT o ABS con filetto 7/8" - 14, riducendo così i costi ed i tempi di fermo macchina nell'attesa che vi vengano consegnati finali speciali ...

Potrete utilizzare i finali standards ed economici di PMS; ridurrete così i vostri costi di manutenzione nonché il tempo dei vostri interventi.



Ugelli speciali

Ugelli ad otturatore

Gli ugelli ad otturatore più economici del mercato: facili da smontare e con ingombro minimo !!!

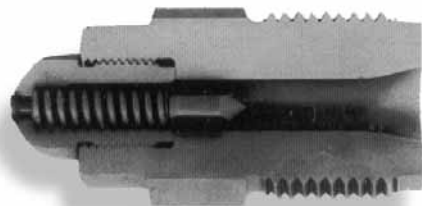

Ugelli a molla esterna o interna, ugelli a contatto. Ideali per risolvere i problemi di smaltimento del materiale.



Ugelli ad otturatore idraulico pneumatico

Contrariamente al modello precedente, la soglia di iniezione si può aprire senza alcuna pressione. Il movimento d'apertura e chiusura è controllato da un martinetto idraulico o pneumatico. Se la pressione eccede i 600 bars, l'ugello si apre automaticamente.

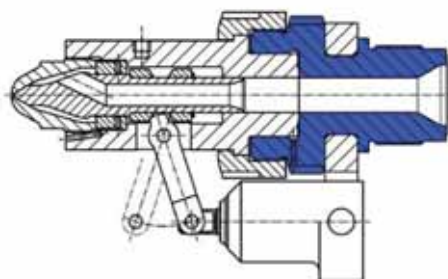

L'ago, che si muove in modo assiale nell'ugello, è tenuto in posizione chiusa grazie alla forza della molla. La pressione del materiale che esce dal canale spinge l'ago indietro e libera l'apertura a partire da 180 bars.

	Molla Interna S20	Leva L20	Molla Interna S30	Leva L30
Flusso iniezione max (PS)	1000 cm ³ / sec		3500 cm ³ / sec	
Diametro vite approx	20 - 60 mm		da 50 mm	
T° max di esercizio	400° C			
Pressione max d'iniezione	2500 bar			
Contropressione max	ca. 200 bar	600 bar	ca. 200 bar	600 bar
Sistema	molla	campe	molla	campe
Orifizio puntale	2 - max. 7 mm		3 - max. 11 mm	
Resistenza ad anello per ugello	diam 45 x 38 mm	diam 50 x 70 mm specifico	diam 70 x 60 mm	diam 70 x 100 mm specifico
Resistenza ad anello per ugello	TL = 60 mm diam 35 x 16 mm		TL = 80 mm diam 55 x 24 mm	
Resistenza ad anello per ugello	TL = 100 mm diam 35 x 55 mm		TL = 120 mm diam 55 x 60 mm	
Termocoppia.	Tipo J, filetto M8x1			



Ugelli monoblocco



Acciaio cromo vanadio trattato per una più lunga durata della vite; lucidato a specchio per garantire un ottimale smaltimento del materiale. Questi ugelli vi porteranno caratteristiche di smaltimento ed una durata della vite molto superiore degli ugelli tradizionali ...

Ugelli grandi modelli

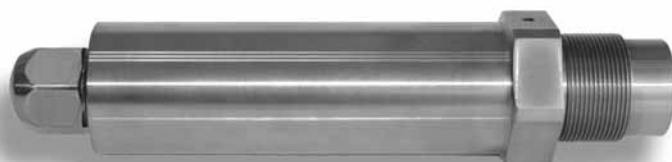

Gli ugelli standard hanno un alesaggio di 12,7 mm di diametro che danno una sezione di passaggio di 127 mm². Questi ugelli grandi modelli hanno un alesaggio di Ø 19 mm che dona una sezione di passaggio di 283 mm² che corrisponde a una capacità d'iniezione di un volume di 21/4 superiore agli ugelli convenzionali...

Ugelli con puntale amovibile

Trattamento termico :
48/52 Hrc - Ugello 28-32 Hrc

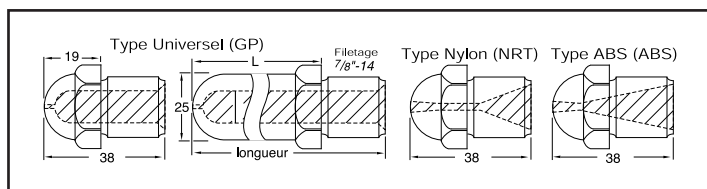

Tutti i nostri ugelli sono concepiti e fabbricati nei siti produttivi PMS e Nickerson.

Prezzo per un sistema completo ugello puntale

Filetto dell'ugello	Lunghezza totale (in mm - puntale incluso)							
	95	125	150	175	200	225	250	300
ø filetto < 51 mm	101,72	115,33	124,40	133,47	142,54	162,01	181,43	194,39
ø filetto tra : 51 mm et 70 mm	149,67	161,98	171,04	181,41	194,37	213,81	233,25	272,12

Prezzo in euro

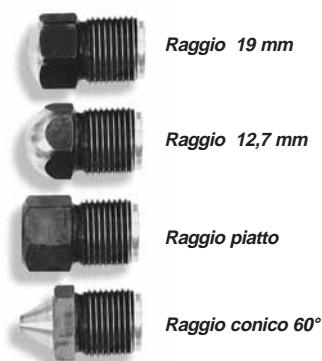

Lunghezza (mm)	Tipo	Ref.	Prezzo speciale unitario in euro		
38 mm	Universale	GP1	23,88	21,49	20,69
	Nylon	NRT1	23,88	21,49	20,69
	ABS	ABS1	24,70	22,23	21,41
70 mm	Universale	GP2	39,52	35,57	34,25
	Nylon	NRT2	39,52	35,57	34,25
	ABS	ABS2	51,33	46,20	44,49
95 mm	Universale	GP3	51,33	46,20	44,49
	Nylon	NRT3	51,33	46,20	44,49
127 mm	Universale	GP4	64,22	57,80	55,65
	Nylon	NRT4	64,22	57,80	55,65

Forno a pirolisi

Pulire senza sforzo:

i vostri ugelli, puntali, valvole, senza deteriorare i vostri pezzi!

Dimensioni utili del contenitore:

350 x 350 x 350 mm

Dimensioni generali del forno:

larg. 700 x prof. 650 x alt. 550 mm

Forno a pirolisi per la pulizia per carbonizzazione delle vostre attrezzature. Apparecchiatura fornita con timer, regolatore di temperatura.

Utilizzabile anche per la pulizia della vite.

Piazzate i vostri ugelli, puntali,... nel contenitore rimovibile e attendete la pulizia completa.

Non più incrostazioni!!!

Basta un semplice colpo di spazzola!!!



3 100,00 €

spese di trasporto incluse

Resistenze

Resistenze a bande

RESISTENZE BLINDATE STAGNE IN OTTONE

Ideale per gli ugelli d'iniezione ...

Forniture di primo impianto dei più affermati fabbricanti europei di presse :

**Arburg / Battenfeld / Boy / Demag
Krauss Maffei / Sandretto.**

Le uscite stagne proteggono dalle infiltrazioni dei materiali. Una concezione perfettamente stagna, con delle connessioni brasate, prevengono dalle infiltrazioni di materiale e prolungano la durata. La qualità della finitura interna di queste resistenze in ottone garantisce un eccellente scambio termico.

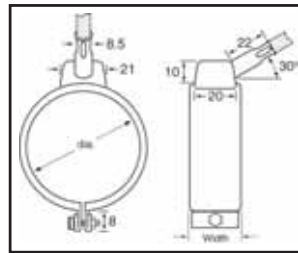

Resistenze blindate stagne in ottone

TENSIONE 230 V

Lunghezza standard della treccia: 500 mm o 1000 mm.

**Nessun
aumento
dal 2002 !**

TIPOMBI

Larghezza	20	25	30	35	40	45	50	55	60	Prezzo
Diametro	Potenza disponibile {Watt}									
25	-	-	100	-	-	-	-	-	-	€ 19,60
30	-	105	125	145	165	-	-	-	-	€ 19,60
35	-	120	145	170	195	220	-	-	-	€ 19,60
40	-	140	165	195	225	250	-	-	-	€ 19,60
42	-	145	175	205	235	-	-	-	-	€ 19,60
45	-	155	190	220	250	285	315	345	-	€ 19,60
50	140	175	210	245	280	-	350	-	420	€ 19,60
55	155	190	230	270	310	-	385	-	-	€ 22,40
60	165	210	250	295	335	-	420	-	505	€ 22,40
65	180	225	275	320	365	-	455	-	550	€ 28,00
70	195	245	295	345	395	-	490	-	590	€ 28,00
75	210	260	315	370	420	-	525	-	635	€ 28,00
80	225	280	335	395	450	-	565	-	675	€ 28,00
85	240	300	360	420	480	-	600	-	720	€ 28,00
90	250	315	380	445	505	-	635	-	760	€ 28,00
95	265	335	400	465	535	-	670	-	800	€ 28,00
100	280	350	420	490	560	-	700	-	840	€ 28,00
65	180	225	275	320	365	-	455	-	550	€ 28,00
70	195	245	295	345	395	-	490	-	590	€ 28,00
75	210	260	315	370	420	-	525	-	635	€ 28,00
80	225	280	335	395	450	-	565	-	675	€ 28,00
85	240	300	360	420	480	-	600	-	720	€ 28,00
90	250	315	380	445	505	-	635	-	760	€ 28,00
95	265	335	400	465	535	-	670	-	800	€ 28,00
100	280	350	420	490	560	-	700	-	840	€ 28,00